

**Columbia River Basin
PIT Tag Information System**

**2003
PIT Tag
Specification Document**

**Prepared by
Pacific States Marine Fisheries Commission
for the
PIT Tag Steering Committee**

November 26, 2003

Compiled and Edited by Carter Stein, Dave Marvin, John Tenney and Nadia Gruman

Table of Contents

I. Overview	4
II. 2003 Changes.....	2
III. Data File Definitions.....	2
A. Tagging File.....	3
B. MiniMon Interrogation File.....	17
C. MULTIMON File.....	19
IV. Code Lists.....	20
A. Species Codes.....	20
B. Run Codes.....	21
C. Rearing Type Codes.....	21
D. Verbose Species Run and Rearing Type Codes.....	21
E. Coordinator ID Codes.....	22
F. Conditional Comments (Flag Codes).....	24
G. Hatchery Codes.....	25
G. Capture Method Codes.....	27
H. Tagging Method Codes.....	28
I. Organization Codes.....	29
J. Tag and Release Site Codes.....	29
K. PIT Tag Steering Committee Members, 2003.....	57
V. Glossary of Terms.....	58
Appendix A. Hydrologic Unit Codes.....	67
A1. Classification System.....	67
A2. Explanation of Hydrologic Unit Codes.....	67
A3. Hydrologic Unit Names.....	68
A4. List of Hydrologic Unit Codes.....	68
Appendix B. Monitor Naming Standards.....	71
B1. Naming Standard for PIT Tag Monitors at Juvenile Fish Facilities.....	71
B2. Naming Standard Example.....	72
Appendix C. Interrogation Site Configurations.....	74
C1. Bonneville Adult Lab (B2A).....	75
C2. Bonneville Dam PH2 (B2J).....	76
C3. Bonneville Dam PH1 (BVX).....	77
C4. Clark Flat Facility (CFJ).....	78
C5. Easton Facility (ESJ).....	79
C6. Little Goose Dam (GOJ).....	80
C7. Lower Granite Adult Trap (GRA).....	81
C8. Lower Granite Dam (GRJ).....	82
C9. Jack Creek Facility (JCJ).....	83
C10. John Day Dam (JDJ).....	84
C11. Lower Monumental Dam (LMJ).....	85
C12. McNary Dam (MCJ).....	86
C13. Prosser Juvenile Trap (PRJ).....	87
C14. Site Configuration History.....	88
Appendix D. GIS Maps.....	98
D1. State of Idaho.....	99

D2. State of Oregon	100
D3. State of Washington	101
D4. Columbia Basin.....	102
Appendix E. Perpetual Day-of-Year Calendars.....	104
E1. Perpetual Day-of-Year Calendar — Non-Leap Years	105
E2. Perpetual Day-of-Year Calendar — Leap Years	106
Appendix F. PTAGIS Database Structure	109
F1. Overview of PTAGIS DBMS Schema	110
F2. Field Data Load (FDVL) Sub-Schema	111
F3. Interrogation Data Load (IDL) Sub-Schema	119
F4. Test Tag (TST) Sub-Schema	124
F5. Site Configuration Management (SCM) Sub-Schema.....	127
F6. Validation SubSchema (VAL).....	131

I. Overview

Passive Integrated Transponder (PIT) tags have been used since 1987 to monitor the movement and behavior of anadromous salmonids in the Columbia and Snake river basins. The PIT Tag Information System (PTAGIS) was implemented in 1991 to manage the collection, correlation, and exchange of Columbia River Basin PIT tag data. PTAGIS encompasses dedicated data collection software, a centralized relational database management system, and standardized data descriptions and reporting processes. In 2002, the scope of the Columbia Basin PTAGIS program was expanded to include entries for resident and semi-anadromous stocks of rainbow and cutthroat trout, bull trout, and lamprey.

There are four general classes of PIT tag events represented in the PTAGIS database. The relationships between these different events are shown in the diagram below. Every unique PIT tag code in the database is expected to have a single **Tag and Release Event**, and a single entry in the database for this event. Subsequent to release, a PIT-tagged fish may be physically recaptured one or more times. Each recapture is a separate **Recapture and Re-release Event**, and each of these events has a separate entry in the PTAGIS database. If, during a recapture event, a PIT-tagged fish dies, or a PIT tag from a previously released fish is recovered, then the observed or inferred death is recorded as a **Mortality Event**, and the PTAGIS database receives a single entry for each such event. Each of these three events is recorded, and reported to PTAGIS, in a **Tagging File**. A single Tagging File may contain entries for any one, two, or all three of the **Tag and Release**, **Recapture and Re-release**, and **Mortality** events.

There are PIT tag interrogation systems deployed at numerous locations throughout the Columbia and Snake river basins. The tag codes of PIT-tagged fish are passively detected when the fish swim through or past one or more transceiver antennas at these locations. Each of these passive interrogations is recorded as an **Interrogation Event**, and entered into an **Interrogation File**. Many interrogation sites employ an array of antennas, resulting in multiple detections per site. In addition, a single anadromous fish may encounter, and be passively detected at, multiple interrogation sites as the fish migrates downstream to the ocean, and yet again as it returns to freshwater to spawn.

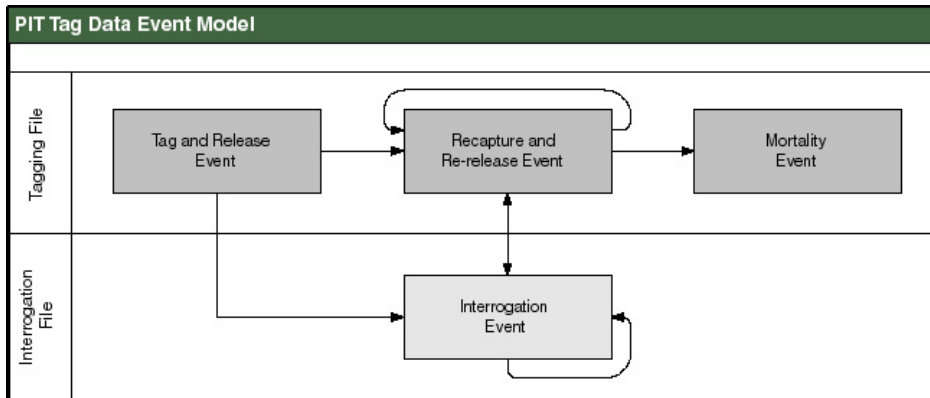

The PTAGIS database has been designed, modified, and refined to incorporate, relate, and report detailed information about PIT-tagged fish, using the four classes of the Data Event Model. This Specification Document has been prepared to ensure that all PIT tag data entry to, and retrieval from, the PTAGIS database is consistent with the Model. Database flexibility exists to modify data inputs as the Model evolves. However, all proposed changes to this document must be reviewed annually by the PIT Tag Steering Committee (PTSC). Review and modification of this Specification

Document will occur annually prior to February. Questions concerning this document should be addressed to PTSC (see **PIT Tag Steering Committee Members**, in Section IV).

II. 2003 Changes

The following is a list of significant changes made to the *2003 PIT Tag Specifications Document*:

1. The PTAGIS Codes Library was modified in 2002 to include definitions for new Species (Bull trout, Cutthroat trout, Pacific Lamprey, White Sturgeon, Green Sturgeon, Pink Salmon and Northern Pike Minnow) and a new "Resident" Run definition. (See Section IV, Code Lists.)
2. The defined length of the Conditional (Flag Codes) field in a tag detail record of a Tagging File has been restored to 50 characters.
3. River Reach Codes definition has been updated. This means that the code COLR is no longer valid, rather the codes COLR1, COLR2...COLR9 should be used instead. See section IV.J.2 for new definition.
4. The initials of the Tag Coordinator are to be used in naming conventions for Tagging Files.
5. The verbose species, run and rearing type descriptor for "Other Species" is now 90U.
6. Variable Release Time (VRT) Declarations have been removed as a component of note records in this specification. VRT's are now described in their own section.
7. Monitored Release Files are no longer used and have been removed from this specification. Use Tagging Files with appropriate flag codes.
8. Mortality Files are no longer used and have been removed from this specification. Use Tagging Files with appropriate flag codes.
9. Release Information Files are no longer used and have been removed from this specification. Use Tagging Files and the Release Information header records or VRT records.
10. "Tag and Release Site Codes" have been renamed to "Mark and Recapture Site Codes".

This document contains the complete versions of the PTAGIS validation code lists as of 11/26/2003. The reader can obtain the latest version of each list directly from the PTAGIS web site at:

<http://www.ptagis.org>

III. Data File Definitions

Three data file types are currently recognized by the PTAGIS system: **Tagging**, **MiniMon Interrogation**, and **MultiMon Interrogation**. All files must be in ASCII format and cannot contain non-printable characters (*e.g.*, <ESC> or <TAB>). Within each data class, all records must comply with the following specifications. The first record of Tagging and MiniMon Interrogation data files will be the "FILE TYPE" record.

Format: "FILE TYPE" starting at line 1 in column 5; a colon (:) in column 36; and the File Type identifier starting in column 38 ("TAGGING" or "INTERROGATION").

A. Tagging File

A **Tagging File** is used to provide information on the marking (and release) of newly marked fish. The **Tagging File** may also include information on the *recapture* and/or *mortality* of previously PIT-tagged fish (see Recapture and Mortality definitions in Section V. Glossary).

PTAGIS will accept Tagging Files created by the **P3.EXE** and **PITTAG2.EXE** programs. PTAGIS will **not** accept files created with the DOS programs **PITTAG.EXE** or **BIOMARK.EXE**. PTAGIS discourages the continued use of the **PITTAG2.EXE** program. The current version of the **P3.EXE** program is available from the PIT Tag Operations Center (PTOC) at the Pacific States Marine Fisheries Commission (PSMFC).

A Tagging File consists of eight possible record categories. (1-4) PTAGIS requires that the Tagging File contain a single record each of the **File Type**, **Program Version**, **Session or Project Message**, and **End of File Record** types, and (5) exactly 19 **Header** records. (6) A tagging file contains zero or more **Tag Detail** records. (7) The inclusion of one or more **Note** records is optional. (8) A **Variable Release Time Definition** records are required for each unique release time variable used in the **Tag Detail** record(s).

In the ASCII output file, each **Tag Detail** record is distinguished by a right justified sequence number in columns 1-4. The contents of all other record types are preceded by spaces (ASCII character 32dec./ØH2Ø) in columns 1-4. The **File Type**, **Program Version**, **Header**, and **End of File Record** definitions are all formatted as follows: the record declaration begins in column five, a colon (":") appears in column 36, and the record contents are displayed beginning in column 38. The individual Tagging File record types are defined in detail below.

1. File Type Record

Format: "FILE TYPE" starting in column 5; a colon (:) in column 36; and "TAGGING" starting in column 38. This record is generated by the software on the first line of the ASCII output file. This is a required record.

```
FILE TYPE                               : TAGGING
```

2. Program Version Record

The only valid program version declarations are:

- PITTAG2.EXE 1.04; OR
- PITTAG3 (version 1.0 or greater)

This record is generated by the software on the second line of the ASCII output file. This is a required record.

3. Session Message

Text, 76 character input maximum. This required record is formatted by the software; and is delimited by dashed sequences on lines three and five of the ASCII output file. While the exact record content is left to the user's discretion, the Session Message should provide a summary of the purpose or scope of the tagging project.

Example 1: Typical Session Message

```
SPCA habitat utilization study in Swimin River  
drainage, 2003
```

4. Header Records

The label contents, order, and format of the header records are standardized and cannot be changed. These are required records. The mandatory inclusion of record contents may be required, as individually noted.

	FIELD NAME	CONTENT	MANDATORY/OPTIONAL
a.	FILE TITLE	xxxYYDDD.zzz	Mandatory
	This required format is auto-generated by the PITTAG2.EXE and P3.EXE programs and consists of a valid tagging data coordinator's ID (initials) and the day-of-year (YYDDD). The contents of the extension (zzz) are left to the discretion of the tagging supervisor. However, as all data files submitted to PTAGIS must have unique titles, it is imperative that the "filename.extension" combination not conflict with any other PIT tag data files generated within the Columbia Basin.		
b.	TAG DATE	MM/DD/YY hh:mm	Mandatory
	This field records the date the tag data was collected. The value is generated by the software, and defaults to the current computer date and time. This value can be modified in PITTAG2.EXE . When the Tagging File contains records of PIT tag releases or recaptures/mortalities collected over multiple days then, by convention, the Tag Date field should contain the first day of sampling effort, the Release Date field (see below) should reference the last day of sampling effort, the actual dates of PIT tag release/recovery should be denoted using Variable Release Times (see below), and the procedure should be documented in a session Note (see below) preceding the first Tag Detail record (see below).		

	FIELD NAME	CONTENT	MANDATORY/OPTIONAL
c.	TAGGER	Lastname I	Mandatory
		This field records the tagging supervisor or primary tagger's last name, followed by a space and first initial, to a maximum of 15 characters.	
d.	HATCHERY SITE	[Valid Hatchery]	Optional
		When fish are tagged at a hatchery, this field contains the four-character abbreviation from the domain of hatchery codes (see Hatchery Codes in Section IV).	
e.	STOCK	Text	Optional
		This field contains a description of the genetic or geographic stock, to a maximum of 15 characters.	
f.	BROOD YR	Nn	Optional
		This field contains the last two digits of the calendar year when eggs were deposited or collected, if known.	
g.	MIGRATORY YR	Nn	Mandatory
		This field contains the last two digits of the earliest possible calendar year when fish will out-migrate. For a recapture/mortality event, or if adults are tagged, this value references the current calendar year.	
h.	TAG SITE	[Valid Tag Site]	Mandatory
		This field contains a code, from the domain of valid Tag and Release Site codes, denoting the site where the fish were marked (see Tag and Release Site Codes in Section IV). When reporting a recapture or mortality event, this code designates the recapture or mortality site.	
i.	RACEWAY/TRANSECT	Text	Optional
		This field contains an abbreviated description of the sampling location, to a maximum of six characters.	
j.	CAPTURE METHOD	[Valid Capture Method]	Mandatory
		This field contains a code, from the domain of valid Capture Method codes, denoting the method by which the fish were collected. (See Capture Method Codes in Section IV.)	
k.	TAGGING TEMP	nn.n	Mandatory
		This field contains the temperature (00.0-25.0°C, inclusive) of the tagging water. A value of 25.0 should be entered if the water temperature is not obtained, or the value varies over the period of time detail tag records are collected.	
l.	POST TAGGING TEMP	nn.n	Optional
		When there is a significant time interval between the marking and release of PIT-tagged fish, this field contains the temperature (00.0-25.0°C, inclusive) of the water in the post-tagging holding facilities (<i>e.g.</i> , an outdoor raceway).	

	FIELD NAME	CONTENT	MANDATORY/OPTIONAL
m.	RELEASE WATER TEMP	nn.n	Cond. Mand.*
	<p>This field contains the temperature (00.0-25.0°C, inclusive) of the water the tagged fish were released into. This field is required when the Tagging File provides Release Information. A value of 25.0 should be entered if the water temperature is not obtained, or the value varies over the period of time detail tag records are released.</p>		
n.	TAGGING METHOD	[Valid Tagging Method]	Mandatory
	<p>This field contains the four-character code, from the domain of valid Tagging Method codes, denoting the method by which PIT tags were inserted into the fish. If all Tag Detail records in the file refer to the recapture or mortality of fish previously tagged, the value is "NONE". (See Tagging Method Codes in Section IV.)</p>		
o.	ORGANIZATION	[Valid Organization]	Mandatory
	<p>This field contains the code, from the domain of valid Organization codes, denoting the agency or entity responsible for the PIT tag marking or recovery activity. (See Organization Codes in Section IV.)</p>		
p.	COORDINATOR ID	[Valid Coordinator ID]	Mandatory
	<p>This field contains the code, from the domain of valid Coordinator ID codes, identifying the individual responsible for the PIT tagging data (not necessarily the person conducting the marking or recovery activity). (See Coordinator ID Codes in Section IV.)</p>		
q.	RELEASE DATE	MM/DD/YY hh:mm	Cond. Mand.*
	<p>This field contains the date and time of Release, in Pacific Standard Time (PST). During a recapture event, this code designates the re-release date. This record is required when the Tagging File provides Release Information. (When the Tagging File contains records of PIT tag releases or recaptures/mortalities collected over multiple days then, by convention, the Tag Date field (see above) should contain the first day of sampling effort. Under these circumstances, the Release Date field should reference the last day of sampling effort, the actual dates of PIT tag release/recovery should be denoted using Variable Release Times (see below), and the procedure should be documented in a session Note (see below) preceding the first Tag Detail record (see below).</p>		
r.	RELEASE SITE	[Valid Release Site]	Cond. Mand.*
	<p>This field contains a code (between four and six characters) denoting the site where the tagged fish were released. When the file contains records detailing recapture or mortality events, this code denotes the mortality site or the re-release site for recaptures. This field is required when the Tagging File provides Release Information (see Tag and Release Site Codes in Section IV).</p>		
s.	RELEASE RIVER KM	nnn(.nnn)	Cond. Mand.*
	<p>This field contains a series of three-digit values, separated by periods, corresponding to the lengths of river segments (in kilometers) between the mouth of the Columbia River and the release site. The length of the field is between three and 27 characters. This field is required when the Tagging File provides Release Information (see Tag and Release Site Codes in Section IV).</p>		

***Cond. Mand (Conditionally Mandatory):** If any of the four header fields related to release information (Release Water Temp, Release Date, Release Site, or Release River KM) is submitted with data, then all four of those header records must contain data. In addition, if Variable Release Times are declared and defined within the Tag Detail records, all four Release Information header records must be completed.

5. Tag Detail Records

Up to 9,999 of these records may appear in the Tagging File.

FIELD NAME, DETAILS	COLU MN #	MAND./OPT.
a. SEQUENCE NUMBER This is a computer-generated value, incremented sequentially, and right-justified, with values between 1 and 9999, inclusive.	1-4	Mandatory
b. PITCODE Left-justified, hexadecimal. Two general formats are permitted. The first consists of a 10-character hex tag code, optionally trailed by the combination of two spaces (32dec./ØH2Ø) and a two-character hex checksum value. This mask is characteristic of 400 kHz PIT Tags. The second format consists of a 14-character hex tag code comprised of a three-character hex country code, a period (ASCII 46dec./ØH2E), and a 10-character hex ID code; this mask is typical of 134.2 kHz ISO-compliant Duplex-B PIT Tags. PTAGIS also recognizes a series of 10 periods as a null value for a PITCODE in either of the above formats.	7-20	Mandatory¹
c. FORKLENGTH Forklength of fish. Integer, right justified, in millimeters.	21-28	Optional
d. WEIGHT Weight of fish. Floating point numeric, right justified, and precise to a tenth of a gram.	29-38	Optional
e. COMMENTS There are three classes of comments: Positional, Conditional, and Textual. These comments are used to describe specific characteristics of individual fish.		
1. POSITIONAL COMMENTS		
Only Positional Comments defined in this specification document may appear in columns 41-45 of the ASCII output file. The Positional Comments currently specified are as follows:		
A. SPECIES Single-digit integer. (See Species Codes in Section IV.)	41	Mandatory
B. RUN Single-digit integer. (See Run Codes in Section IV.)	42	Mandatory

¹ PIT Tags can only be re-used in the Columbia River system if each tag is removed from the fish and the tag code is removed or changed to ten periods (.) prior to the Tagging File being submitted to PTAGIS. All other fields in the record should remain intact for future reference. PIT Tags from recaptured fish CAN NOT be re-used, and must NOT be "dotted out."

FIELD NAME, DETAILS	COL. #	MAND./OPT.
C. REARING TYPE Single-character text. (See Rearing Type Codes in Section IV.)	43	Mandatory

See Section IV.D for a list of the Verbose Species, Run and Rearing Type codes

FIELD NAME, DETAILS	COL. #	MAND./OPT.
D. RELEASE TIME VARIABLE	44-45	Optional
<p>Two digits. This value allows users to specify multiple release times for Tag Detail records in a single file. Valid values are 00-99, inclusive. Each unique Release Time Variable used must have a corresponding Release Time Variable Definition that reports the actual date and time of release. (See 7.Variable Release Time Definitions in Section III.7.)</p> <p>When the Tagging File contains records of PIT tag releases or recaptures/mortalities collected over multiple days then, by convention, the Tag Date field (see above) should contain the first day of sampling effort. Under these circumstances, the Release Date field (see above) should reference the last day of sampling effort, the actual dates of PIT tag release/recovery should be denoted using Variable Release Times (see below), and the procedure should be documented in a session Note (see below) preceding the first Tag Detail record.</p>		
E. ADDITIONAL POSITIONAL COMMENTS	Var.	Optional
<p>Up to 45 columns of Additional Positional Comments, required by individual research projects, may appear after column 45. These Additional Positional Comments are not recorded into the PTAGIS database.</p>		
2. CONDITIONAL COMMENTS	Var.	Optional
<p>Conditional Comments, also known as Flag Codes, are used to systematically catalog a variety of morphological, environmental, and logical factors associated with a specific tagged fish. Conditional Comments, if present, appear after any Additional Positional Comments and are preceded by a single vertical bar symbol (" ", ASCII 124dec./ØH7C) and are delimited with a single space. This field can hold up to 50 characters, including the space separators. Only Conditional Comments approved by the PTSC will be recognized by PTAGIS. (See Conditional Comments (Flag Codes) in Section IV.)</p>		

FIELD NAME, DETAILS	COL. #	MAND./OPT.
---------------------	--------	------------

By default, the **Tag Detail Record** describes a new **Tagging** event. However, the presence of specific Flag Codes in the Tag Detail Record denote either a **Recapture** or **Mortality** event, as described below.

Recapture Events: A recapture is defined as a previously PIT-tagged fish that is handled subsequent to the release event. The Tagging File is used to record recaptures. The flag code **RE** must be added to each recapture tag record in the Tagging File. If all of the tag records in the Tagging File reference recaptured fish, then the Header records will also reference those Recapture Events. In such a case, for example, the Tag Site will actually denote the Recapture Site, and the Release Date will serve as the re-Release Date.

Mortality Events: A mortality is defined as a PIT tag that is recovered, with or without its host animal, subsequent to the tagged release of that animal. One of the defined mortality flag codes (**M, MB, MK, MS, L, SM**) must be added to each corresponding mortality tag record in the Tagging File. PIT Tags recovered from Mortality Events are to be returned to the PTOC, if possible. The death of tagged fish and/or the retrieval of those tags prior to release are not considered to be Mortality Events. Under such circumstances, the original owner of the tag can remove ("dot-out") the reference to that tagging event in the original Tagging File, submit the corrected Tagging File to PTAGIS, and then re-use the tag as part of a new tagging event.

Adult Returns: PIT-tagged fish returning to spawning locations may be recorded as Tagging, Recapture, or Mortality events. In addition to any required recapture or mortality code, all returning fish should be flagged with an **RF** code, plus an **MT** (for "Mature"), **KL** (for "Kelt"), **JA** (for "Jack"), or **MJ** (for "MiniJack") code, as appropriate.

3. TEXTUAL COMMENTS Var. Optional

Textual Comments are separated from Conditional Comments by a single vertical bar symbol. If no Conditional Comments are present, Textual Comments are preceded by two vertical bar symbols "||" and consist of information specific to the individual fish. This field can hold up to 50 alphanumeric characters, including ASCII punctuation. The contents of this field are unregulated by PTAGIS. By convention, Textual Comments are *ad hoc* annotations unique to individual tag detail records rather than a common descriptor duplicated in all tag detail records.

6. Note Records

Most Note Records are *ad hoc* annotations to the data file. Global comments pertaining to the tagging session are generally entered between the header and first Tagging Detail record, using **the Session Note** function in **P3.EXE** or **PITTAG2.EXE**. Additional comments can be added during the tagging session. The format and content of all Note Records are ignored by PTAGIS.

7. Variable Release Time Declaration Records

Format: VARIABLE RELEASE TIME DECLARATION: (One required for each unique release time variable used in the Tagging Detail records.) The VRT declaration begins with an upper case "V" in column five, followed by the two digit release variable (nn) in columns six and seven, an equals sign "=" in column eight, the two digit month (MM) in columns nine and ten, a slash (/) in column 11, the two digit day (DD) in columns 12 and 13, a slash (/) in column 14, the two digit year (YY) in columns 15 and 16, a space in column 17, the two digit military-style hour (hh, 00-23) of release, in Pacific Standard time, in column 18 and 19, a colon (:) in column 20, and the two digit minutes (mm) of release in columns 21 and 22.

Vnn=MM/DD/YY hh:mm

e.g., V01=04/08/01 16:45

When the Tagging File contains records of PIT tag releases or recaptures/mortalities collected over multiple days then, by convention, the Tag Date field (see above) should contain the first day of sampling effort. Under these circumstances, the Release Date field (see above) should reference the last day of sampling effort, the actual dates of PIT tag release/recovery should be denoted using Variable Release Times, and the procedure should be documented in a session Note (see above) preceding the first Tag Detail record (see above).

8. End of File Record

The End of File record uses the same positional formatting as HEADER records. The record is created by the software and is required by PTAGIS as the last record in the file.

Format: CLOSE DATE: Beginning in column 5, a colon (":") at column 36, and a date/time stamp (MM/DD/YY hh:mm) starting at column 38. The time is formatted as Pacific Standard Time (PST).

14 : 50

CLOSE DATE

: 06/09/03

Example 2. Tagging File with Predominantly New Tags

```
FILE TYPE           : TAGGING
PROGRAM VERSION     : PITTAG3 1.0.4
-----
TAGGING FILE EXAMPLE FOR 2003 SPECIFICATION DOCUMENT
-----
```

```
FILE TITLE          : ATL03118.KF1
TAG DATE            : 04/28/03 04:30
TAGGER              : LOSER A
HATCHERY SITE      :
STOCK               :
BROOD YR            :
MIGRATORY YR       : 03
TAG SITE            : KILFAT
RACEWAY/TRANSECT   :
CAPTURE METHOD      : SCREW T
TAGGING TEMP        : 8.9
POST TAGGING TEMP   :
RELEASE WATER TEMP  : 8.9
TAGGING METHOD       : HAND
ORGANIZATION        : SPCA
COORDINATOR ID     : ATL
RELEASE DATE        : 04/28/03 05:15
RELEASE SITE        : KILFAT
RELEASE RIVER KM    : 999.748.048
```

MARKING AT KILLUM FALLS TRAP FOR AMERICAN SPCA. ONLY SALMONIDS MARKED.
ALL FISH CAPTURED WERE TREATED WITH RESPECT AND WITHOUT CONSIDERATION OF
EXTERNAL APPEARANCE, ECONOMIC IMPORTANCE, OR POSITION IN FOOD CHAIN.

CLIP #Z194

```
1 1F5F6B187F      231          32H01   | AD |
2 1F565D5A54      223          32H01   | AD LV |
3 .....          133          32H01   | AD L |
```

THE BRUTE RESPONSIBLE FOR THE MURDER ABOVE HAS BEEN FIRED.

```
4 1F56304D0E      111          11H01   | AD RV |
5 200F03034B      118          11W01   | |
6 1F5F47310A      190          32H01   | AD 1> |
7 1F562F726A      213          32H01   | AD LV |
8 200F0E3112      240          32H01   | AD |
```

< TIME CHECK > 04 APRIL 2003 AT 07:02

```
9 200F0E6E55      246          32W02   | RE |
10 1F57080B77     262          32H02   | AD LV
11 200F1D072D     186          32W02   | GS |
12 524336416C     224          110.7   32H02RART4| AD <2 PB| ROCKING "T" FREEZE BRAND
```

```
1234 3D9.12349809D4 137          15.6   90U   ||COCKROACH. BIG SUCKER.
```

WITHOUT A VARIABLE RELEASE DECLARATION, THE PREVIOUS RECORD USES THE
DEFAULT RELEASE DATE/TIME PROVIDED IN THE HEADER.

```
1235 3D9.42D980FD14 137          15.6   11H05   ||
1236 3D9.5612FE09D3 104          11H05   ||
1237 3D9.7DCA27F3B1 185          25.1   32W05   ||
```

```
V01=04/28/03 06:30
V02=04/28/03 07:20
V03=04/28/03 07:50
V04=04/28/03 07:55
V05=04/28/03 08:15
```

```
CLOSE DATE           : 04/28/03 09:34
```

Example 3. Tagging File Containing Recaptures of Previously-Tagged Fish

```
FILE TYPE           : TAGGING
PROGRAM VERSION     : PITTAG3 1.0.4
-----
2003 SPCA HABITAT UTILIZATION AND BEHAVIOR STUDY; PIT TAG RECAPTURES
-----

FILE TITLE         : ATL03091.KF1
TAG DATE          : 04/01/03 10:30
TAGGER            : LOSER A
HATCHERY SITE     :
STOCK             :
BROOD YR         :
MIGRATORY YR     : 03
TAG SITE         : KILFAT
RACEWAY/TRANSECT :
CAPTURE METHOD    : SCREW T
TAGGING TEMP     : 10.0
POST TAGGING TEMP :
RELEASE WATER TEMP : 10.0
TAGGING METHOD    : NONE
ORGANIZATION     : SPCA
COORDINATOR ID   : ATL
RELEASE DATE     : 06/03/01 12:00
RELEASE SITE     : KILFAT
RELEASE RIVER KM : 999.748.048
```

SEASONAL SUMMARY OF PIT TAG RECAPTURES AT KILLUM FALLS TRAP. SAMPLING OCCURRED 24x7 BETWEEN 4/1/03 AND 6/1/03, AS SHOWN IN THE TAG DATE AND HEADER RELEASE DATE FIELDS. TRAP WAS CHECKED DAILY. COLLECTED FISH WERE RE-RELEASED 100M ABOVE TRAP.

WHEN USING P3.EXE OR PITTAG2.EXE, A NOTE IN THE TAG DETAIL SECTION IS LOGICALLY ASSOCIATED WITH THE TAG DETAIL RECORD IN WHICH IT IS CREATED, BUT THE NOTE IS REPORTED BELOW THAT TAG DETAIL RECORD IN THE ASCII TAGGING FILE. IF TAG DETAIL NOTES ARE CREATED AS VISUAL, RATHER THAN LOGICAL, CUES, THEN IT'S MORE LEGIBLE TO REFERENCE THOSE RECORDS HERE IN THE SUMMARY. SO...

THE ADULT IN RECORD #5 WAS RETRIEVED FROM THE MOUTH OF THE TRAP, SCANNED, AND ALLOWED TO RECOVER BEFORE BEING RE-RELEASED UPSTREAM.

REGARDING THE FISH IN RECORD #1236: HE'S DEAD, JIM.

1	3D9.1F5F6B187F	231	32H01	RE AD
2	3D9.1F565D5A54	223	32H01	RE AD LV
3	3D9.1E004238E5	133	15U02	RE
4	3D9.1F56304D0E	111	15H03	RE AD RV
5	200F03034B	818	15W04	RE RF MT MA PRE-SPAWNER
6	3D9.1F5F47310A	190	32H05	RE AD 1>
	...			
	...			
1235	3D9.42D980FD14	137	15.6 45W78	RE
1236	3D9.5612FE09D3	104	15H78	RE AD >2 M IMPINGED BY DEBRIS
1237	3D9.7DCA27F3B1	185	25.1 32W79	RE

```
V01=04/02/03 12:00
V02=04/03/03 12:00
V03=04/05/03 12:00
V04=04/06/03 12:00
V05=04/08/03 08:15
```

...

```
V78=05/29/03 12:00
V79=05/30/03 12:00
```

```
CLOSE DATE           : 06/28/03 09:34
```

Example 4. Tagging File Containing Mortalities of Previously-Tagged Fish

```
FILE TYPE           : TAGGING
PROGRAM VERSION     : PITTAG3 1.0.4
-----
2001 RETURNS TO SWIMIN HATCHERY
-----

FILE TITLE         : ATL03091.SIH
TAG DATE          : 04/01/03 10:30
TAGGER            : LOSER A
HATCHERY SITE     :
STOCK             :
BROOD YR         :
MIGRATORY YR     : 03
TAG SITE         : SWIH
RACEWAY/TRANSECT :
CAPTURE METHOD    : HATCH
TAGGING TEMP     : 10.0
POST TAGGING TEMP :
RELEASE WATER TEMP : 10.0
TAGGING METHOD    : NONE
ORGANIZATION     : SPCA
COORDINATOR ID   : ATL
RELEASE DATE     : 09/03/01 12:00
RELEASE SITE     : SWIH
RELEASE RIVER KM : 999.888.777
```

SEASONAL SUMMARY OF PIT TAG RETURNS TO SWIMIN HATCHERY IN 2003. COLLECTION INCLUDED NATURAL AND SUPPLEMENTATION STOCKS. THESE WERE SEGREGATED, TUBE-SCANNED, AND RETURNED TO THE SWIMIN RIVER DAILY. ALL HATCHERY STOCK WERE COLLECTED, SCANNED, AND SPAWNED. ADULTS WERE PONDED FROM 4/01 THROUGH 9/01/03, AS SHOWN IN THE TAG DATE AND HEADER RELEASE DATE FIELDS. THE ACTUAL DATES OF TAKE OR RE-RELEASE ARE REPORTED IN THE DETAIL RECORDS.

1	3D9.1F5F6B187F	834	12H01	RF MT RE M
2	7F7F5D5A54	982	12H01	RF MT RE M
3	7F7E4238E5	913	12H02	RF MT RE M
4	3D9.1F56304D0E		15U03	RF MT RE NATIVE
5	200F03034B	1043	12H04	RF MT RE M
6	3D9.1F5F47310A	967	12H05	RF MT RE M

...
...

272	7F7D629176		15U78	RF MT RE NATIVE
273	3D9.5612FE09D3	982	12H78	RF MT RE M
274	3D9.7DCA27F3B1	991	12H79	RF MT RE M

V01=04/08/03 12:00
V02=04/09/03 12:00
V03=04/19/03 12:00
V04=04/20/03 12:00
V05=04/21/03 08:15

...
...

V78=08/19/03 12:00
V79=08/28/03 12:00

CLOSE DATE : 09/21/03 15:12

B. MiniMon Interrogation File

Interrogation files are computer-generated using the *MINIMON.EXE* program. The format is described below. Interrogation Site Codes, System ID Codes, and Coil ID codes are typically assigned by the PIT Tag Operations Center (PTOC) when a new system is installed.

Interrogation files consist of five record categories: **File Type**, **Start Message Records**, **Interrogation Data Records**, **Other Record Types**, and an **End of File Record**.

1. File Type Record

Format: "FILE TYPE" starting at line 1 in column 5; a colon (:) in column 36; and "INTERROGATION" starting in column 38. This record is generated by the software on the first line of the ASCII file. This is a required record.

```
FILE TYPE                               : INTERROGATION
```

2. Start Message Records

FIELD NAME	MANDATORY
a. FILE TITLE	Mandatory
File Titles are a maximum of 12 characters. The format consists of a three-character site code, two-digit year, and three-digit day-of-year. The alphabetic extension is reserved for partitions (e.g., DOJ01114.A). This record is generated by the software on the second line of the ASCII file. This is a required record.	
b. FILE CREATED	Mandatory
Date and time (e.g., 24 April 2001 AT 16:45). This record is generated by the software on the third line of the ASCII file. This is a required record.	

3. Interrogation Data Records

Individual records consist of the following required components. **Optional.**

FIELD NAME	FORMAT	COLUMN #
a. DATA TOKEN	" " (a "vertical bar" or "pipe" symbol, ASCII 124dec./ØH7C)	1
b. PORT ID	2-char Hexadecimal	3-4
c. DATE	MM/DD/YY	6-13
d. TIME	hh:mm:ss (PST)	15-22
e. PITCODE	14-char (3.10) Hexadecimal	24-37
f. CHECKSUM	"XX"	39-40
g. COIL ID	2-char Hexadecimal	42-43

4. Other Record Types

- a. Status and Warning Messages **Optional**

Records prefaced with a tilde ("~") in the first column contain information regarding site and transceiver operations.

- b. Blank Lines **Optional**

5. End of File Record

- c. **FILE CLOSED** **Mandatory**

Date and time (e.g., 24 April 2001 AT 20:45). This record is generated by the software on the last line of the ASCII file.

Test Tags: Test tags are used to monitor the operation of an interrogation unit. There are two types of test tags. The first type is referred to colloquially as a **stick tag**, or formally as a **Variable Reference Tag**. These tags are usually embedded in a piece of wood and passed through the detection field of a monitor. At least 10 test tags should be passed through remote interrogation systems daily, if possible, to ensure the system is functioning. The second type of test tag is referred to colloquially as a **timer tag** or formally as a **Fixed Reference Tag**. These "tags" are passive, electronic devices powered by the electro-magnetic field of the interrogation unit they are testing. Each timer tag is permanently mounted in the unit and fires at a specified frequency.

ALL TEST TAGS MUST BE REGISTERED WITH PTOC BEFORE USE.

Example 5. Interrogation File

```
FILE TYPE           : INTERROGATION
FILE TITLE          : DOJ01121.C
FILE CREATED        : 30 APRIL 2001 AT 12:00

~04/30/01 13:00:05
| 06 04/30/01 13:09:05 3D9.1BF0F0DC2F XX 10
| 05 04/30/01 13:09:06 3D9.1BF0F0DC2F XX 11
~04/30/01 14:00:05
~04/30/01 15:00:04
| 06 04/30/01 15:01:51 3D9.1BF0E974D5 XX 10
| 05 04/30/01 15:01:52 3D9.1BF0E974D5 XX 11
| 06 04/30/01 15:22:51 3D9.1BF0E59874 XX 10
| 05 04/30/01 15:22:52 3D9.1BF0E59874 XX 11
| 06 04/30/01 15:33:13 3D9.1BF0F123E1 XX 10
| 05 04/30/01 15:33:14 3D9.1BF0F123E1 XX 11
| 06 04/30/01 15:49:10 3D9.1BF0E677B0 XX 10
| 05 04/30/01 15:49:11 3D9.1BF0E677B0 XX 11
| 06 04/30/01 15:56:29 3D9.1BF0E68597 XX 10
| 05 04/30/01 15:56:30 3D9.1BF0E68597 XX 11
~04/30/01 16:00:03
| 06 04/30/01 16:07:42 3D9.1BF0F195C7 XX 10
| 05 04/30/01 16:07:43 3D9.1BF0F195C7 XX 11
| 06 04/30/01 16:07:44 3D9.1BF0E96F68 XX 10
| 06 04/30/01 16:33:06 3D9.1BF0F5D3EF XX 10
| 05 04/30/01 16:33:07 3D9.1BF0F5D3EF XX 11
~04/30/01 17:00:03
| 06 04/30/01 17:19:11 3D9.1BF0E67D24 XX 10
| 05 04/30/01 17:19:12 3D9.1BF0E67D24 XX 11
| 06 04/30/01 17:45:17 3D9.1BF0E6A631 XX 10
| 05 04/30/01 17:45:18 3D9.1BF0E6A631 XX 11
~04/30/01 18:00:02

FILE CLOSED           : 30 APRIL 2001 AT 18:00
```

C. MULTIMON File

The **MULTIMON.EXE** program has been developed by the National Marine Fisheries Service (NOAA Fisheries) for the interrogation of PIT-tagged fish at mainstem Columbia and Snake river collection and sampling facilities. In addition to simply recording interrogation data, **MULTIMON.EXE** is designed to react to the presence of specific fish and trigger electrical or mechanical operations to control the routing of those fish through research facilities. This capability is a keystone of current and proposed Separation by Code activities. The **MULTIMON.EXE** ASCII file output includes not only interrogation records, but configuration and diagnostic records relating to the program's logical processes.

NOAA Fisheries continues to develop the **MULTIMON.EXE** program, and the format and content of the various record types is subject to change. Please contact PTOC with any questions regarding the content or format of **MULTIMON.EXE** output records, or the current status of program development.

IV. Code Lists

The following are lists of standardized codes used in the Columbia River Basin PIT Tag Information System (PTAGIS). If tagging coordinators have additional codes they would like to use, please submit these to your organization's PIT Tag Steering Committee (PTSC) member for review and approval by the PTSC and inclusion in the next Specification Document.

The code domains listed below are correct and complete as of [INSERT PUBLICATION DATE HERE]. However, codes may be added or modified at any time. The current values of all code lists in the *2003 PIT Tag Specification Document* can be accessed and downloaded from the Internet at: <http://www.ptagis.org>

A. Species Codes

All detail data records in files submitted to the PTAGIS database must contain a Valid Species Code.

Code	Species
0	Unknown
1	Chinook
2	Coho
3	Steelhead
4	Sockeye
5	Chum
6	Pink
7	Bulltrout
8	Cutthroat
9	Other
A	Lamprey
B	White Sturgeon
C	Green Sturgeon
D	Northern Pikeminnow

B. Run Codes

All detail data records in files submitted to the PTAGIS database must contain a valid Run Code.

Code	Run
0	N/A
1	Spring
2	Summer
3	Fall
4	Winter
5	Unknown
R	Resident

C. Rearing Type Codes

All detail data records in files submitted to the PTAGIS database must contain a valid Rearing Type Code.

CODE	REARING TYPE
H	Hatchery Origin
U	Unknown Origin
W	Wild Fish or Natural Production

D. Verbose Species Run and Rearing Type Codes

Code	Verbose Description
00U	Unknown (fish not observed)
11H	Hat. Spring Chinook
11U	Spring Chinook (unknown r/t)
11W	Wild Spring Chinook
12H	Hat. Summer Chinook
12U	Summer Chinook (unknown r/t)
12W	Wild Summer Chinook
13H	Hat. Fall Chinook
13U	Fall Chinook (unknown r/t)
13W	Wild Fall Chinook
15H	Hat. Chinook (unknown run)
15U	Chinook (unknown run & r/t)
15W	Wild Chinook (unknown run)
25H	Hat. Coho

25U	Coho (unknown r/t)
25W	Wild Coho
32H	Hat. Summer Steelhead
32U	Summer Steelhead (unknown r/t)
32W	Wild Summer Steelhead
35H	Hat. Steelhead (unknown run)
35U	Steelhead (unknown run & r/t)
35W	Wild Steelhead (unknown run)
3RH	Hat. Rainbow Trout
3RU	Rainbow Trout (unknown r/t)
3RW	Wild Rainbow Trout
42H	Hat. Summer Sockeye
42U	Summer Sockeye (unknown r/t)
42W	Wild Summer Sockeye
45H	Hat. Sockeye (unknown run)
45U	Sockeye (unknown run & r/t)
45W	Wild Sockeye (unknown run)
65W	Wild Pink
7RW	Bulltrout
85H	Hat. Coastal Cutthroat
85U	Coastal Cutthroat (unknown r/t)
85W	Wild Coastal Cutthroat
8RW	Wild Resident Cutthroat
90U	Other
A0W	Lamprey
B0W	White Sturgeon
C0W	Green Sturgeon
D0W	Northern Pikeminnow

E. Coordinator ID Codes

The Coordinator ID code is the (two or three) initials of the project leader responsible for the PIT Tag data (not necessarily the person conducting the tagging or creating the Tagging File). Data files submitted to the PTAGIS database must contain a valid, recognized Coordinator ID code.

Coord ID	Name, Agency/Org
AAB	Alan Byrne, IDFG
ACG	Andrew Grassell, CPUD
AFB	Arnie Brimmer, IDFG
AFE	Allen Evans, CRITFC
ALS	Ann Setter, ODFW
APR	Andrew Reasoner, DUCKSU
BAR	Brad Ryan, NMFS
BCJ	Brian Jonasson, ODFW

Coord ID	Name, Agency/Org
BDA	Bill Arnsberg, NPT
BDW	Bruce Watson, YINN
BHM	Bruce Monk, NMFS
BRB	Brian Beckman, NMFS
CAP	Chris Peery, ICFWRU
CAR	Chris Reighn, ShoBan
CCP	Charlie Cochran, WDFW
CFB	Cyndi Baker, DUCKSU
CFM	Charles Morrill, WDFW

Coord ID	Name, Agency/Org
CM	Christine Mallette, ODFW
CRC	Craig Contor, CTUIR
CSM	Scott McCutcheon, BIOMRK
DAB	Dean Brege, NMFS
DAC	Dave Cannamela, IDFG
DAN	Duane A. Neitzel, PNL
DAW	David Wills, USFWS
DBJ	David Johnson, NPT

Coord ID	Name, Agency/Org
DDT	Doug Taki, ShoBan
DJN	Doug Nemeth, IDFG
DMM	Doug Marsh, NMFS
DPC	Doug Cramer, PGE
DPM	Dave Marvin, PSMFC
DRH	Doug Hatch, CRITFC
DTL	David Lind, YINN
DTV	Dimitri Vidergar, IDFG
EEH	Eric Hockersmith, NMFS
EFP	Earl Prentice, NMFS
EJL	Eric Leitzinger, IDFG
EMD	Earl Dawley, NMFS
EVD	Erick Van Dyke, ODFW
EWB	Ed Buettner, IDFG
FAG	Fred Goetz, COE
GAA	Gordon Axel, NMFS
GAM	Geoff McMichael, PNL
GBZ	Gayle Zydlewski, USFWS
GES	Gene Shippentower, CTUIR
GSH	Glen Holmberg, USGS
HLB	Howard Burge, USFWS
IGJ	Ian Jezorek, USGS
JAH	Jay Hesse, NPT
JAS	Jen Stone, USFWS
JDZ	Joe Zydlewski, USFWS
JJL	Jeff Lutch, IDFG
JJP	Jay Pravecck, IDFG
JKB	Jody Brostrom, USFWS
JKF	Jeff Fryer, CRITFC
JLC	Jim Congleton, ICFWRU
JLH	Lance Hebdon, IDFG
JLV	Jason Vogel, NPT
JMH	Jon Hansen, NPT
JMO	Jill Olson, USFWS
JNL	Jerry Lockhart, NPT

Coord ID	Name, Agency/Org
JPA	Jeff Abrams, IDFG
JPW	Jody Walters, IDFG
JRH	Jim Harbeck, NPT
JVT	J. Vince Tranquilli, ODFW
KAA	Kim Apperson, IDFG
KB	Kent Ball, IDFG
KEP	Kurtis E. Plaster, IDFG
KFT	Ken Tiffan, USGS
KGM	Keely Murdoch, YINN
KMC	Ken Collis, CRITFC
LCS	Lowel Stuehrenburg, NMFS
LGG	Lyle Gilbreath, NMFS
LRB	Larry Basham, FPC
MBE	Brad Eppard, NMFS
MBL	Mike Lambert, CTUIR
MHG	Michael Gessel, NMFS
MLB	Mike Blenden, NPT
MLS	Mark Schuck, WDFW
MPF	Mike Faler, USFWS
MRC	MAtt Cooper, USFWS
NRB	Nathan Brindza, IDFG
PAK	Paul Kucera, NPT
PCS	Carter Stein, PSMFC
PEB	Patricia Bigelow, USFWS
PHB	Phaedra Budy, UCFWRU
PJC	Peter Cleary, NPT
PKL	Paul Kline, IDFG
PMS	Paul Sankovich, ODFW
PTL	Peter Lofy, CTUIR
RBK	Russ Kiefer, IDFG
RBR	Ralph Roseberg, USFWS
RDL	Dick Ledgerwood, NMFS
RDM	Rick Martinson, NMFS
RFA	Randy Absolon, NMFS
RFW	Robert Warren, SEARES

Coord ID	Name, Agency/Org
RGP	Russell Porter, PSMFC
RHW	Robert Wertheimer, COE
RKS	Kirk Schroeder, ODFW
RLT	Rosanna Tudor, WDFW
RMC	Robert McDonald, CPUD
RMK	Robert Keith, ShoBan
RNI	Robert Iwamoto, NMFS
RPM	Bob Mueller, PNL
RWS	Wes Stonecypher, ODFW
SA	Steve Achord, NMFS
SCS	Sherman Sprague, NPT
SGH	Steve Hays, CPUD
SJB	Steve Boe, CTUIR
SJR	Steve Rocklage, NPT
SMF	Shannon Focher, ODFW
SPR	Steve Rubin, USGS
TAF	Tom Flagg, NMFS
TBH	Terry Holubetz, IDFG
TCB	Ted Bjorn, ICFWRU
TDR	T. Dean Rhine, IDFG
TER	Tom Ruehle, NMFS
TGC	Tim Cochnauer, IDFG
TLL	Theresa Liedtke, USGS
TRM	Thaddeus Mosey, CPUD
TRW	Tim Walters, ODFW
TSC	Tom Curet, IDFG
WAC	Will Cameron, ODFW
WDM	William Muir, NMFS
WHW	Wayne Wilson
WJB	Bill Bosch, YINN
WPC	William Connor, USFWS

F. Conditional Comments (Flag Codes)

Code	Comment
0	Possible 0-Aged Chinook
1<	Descaled Less than 10 Percent
1>	Descaled Greater than 10 Percent
1P	Descaled - Patchy
1S	Descaled - Scattered
<2	Descaled Between 11 and 20%
>2	Descaled Greater than 20%
AD	Adipose Fin Clip
AF	Adipose Fin Damage
AI	Adipose Intact (not clipped)
AN	Anal Fin Damage
AT	Tagged as Adult
B	Bleeding after Tagged
BL	Bloated
BR	Brood Stock
BS	Body Scars
BT	Bare Tag Recovered after Release
CA	Caudal Fin Damage
CW	Coded Wire Tag
CY	Cyst
D	Dropped
DB	Double PIT-tagged
DF	Dorsal Fin Damage
DI	Deep Insertion
DK	Dark Body Color
DO	Dis-orbited Eye
DT	Duplicate Tag
EB	Electro-Shocker Burn
EJ	Elastomer Jet / Photonic Fin Mark
EL	Damaged Eye - Left - after Tagging
EM	Excessive Mucous
ER	Damaged Eye - Right - after Tagging
FE	Female
FU	Fungus
FX	Fish Examination
GB	Gas Bubble Trauma
GS	Gill Sample
HE	Hemorrhage
I	Body Injury - Prior to Tagging

Code	Comment
IM	Immature
JA	Jack
JT	Jaw Tagged
JW	Jaw Damage
KD	Possible BKD
KL	Kelt
L	Fish Lost/Rejected Tag before Release
LA	Lacerations
LF	Large Flume from Separator
LP	Left Pectoral Fin Ray Sample
LT	Light Body Color
LV	Left Ventral Fin Clip
M	Mortality
MA	Male
MB	Bleeding at Tagging/Died Pre-Release
MK	Removed from Release Group (Killed)
MS	Sample Mort (Intentional Sacrifice)
MT	Mature
NF	Non-Functional Tag also in Fish
NM	No Mucous
OP	Opercule Damage
PA	Parasite
PB	Previously Branded
PC	Poor Fin Clip
PD	Peterson Disc
PR	Precocious
PT	Pectoral Fin Damage
PV	Pelvic Fin Damage
Q1	Complete and Legible Freeze Brand
Q2	Brand is Legible but Incomplete
Q3	Brand is not Legible
Q4	Brand Rotation or Position Wrong
Q5	No Brand
Q6	Brand Caused Light to Excessive Burn
RE	Recapture

Code	Comment
RF	Returning Fish
RP	Right Pectoral Fin Ray Sample
RT	Radio Tagged
RV	Right Ventral Fin Clip
SC	Scoliosis
SF	Small Fish Flume from Separator
SM	Subsequent Mort
SP	Spaghetti Tag
ST	Streamer Tag

Code	Comment
SU	Surgery
SV	Silvery Body Color
TM	Tagged In Muscle
UL	Ulcer
VI	Visual Implant / Eye Adipose
WD	Possible Whirling Disease
X	Duplicate Tag for Pre-Release Mort
Y	Possible Age One (Yearling)

G. Hatchery Codes

Code	Hatchery
ABEH	Abernathy SCTC
BEAH	Beaver Creek Hatchery
BIGC	Big Creek Hatchery (ODFW)
BONH	Bonneville Hatchery
CARS	Carson NFH
CASC	Cascade Hatchery
CASS	Cassimer Bar Hatchery
CHEL	Chelan PUD Hatchery
CLAH	Clackamas Hatchery
CLEE	Cle Elum Hatchery
CLWH	Clearwater Hatchery
COWS	Cowlitz Salmon Hatchery
COWT	Cowlitz Trout Hatchery
CROP	Crooked River Rearing Pond
DWOR	Dworshak NFH
EAGH	Eagle Creek NFH
EAGL	Eagle Hatchery
EBNK	East Bank Hatchery Facility
ELRH	Elochoman River (Washington) Hatchery
ENTH	Entiat NFH
GNAT	Gnat Creek Hatchery
GRAY	Grays River Hatchery
HAGE	Hagerman NFH
IRRI	Irrigon Hatchery
ISQH	Issaquah Hatchery
KALA	Kalama Falls Hatchery

Code	Hatchery
KLAS	Klaskanine Hatchery
KLIH	Klickitat Hatchery
KOOS	Kooskia NFH
LEAB	Leaburg Hatchery
LEAV	Leavenworth NFH
LEWH	Lewis River Hatchery
LOOH	Lookingglass Hatchery
LOWK	Lower Kalama Hatchery
LWSH	Little White Salmon NFH
LYFE	Lyons Ferry Hatchery
MARI	Marion Forks Hatchery
MAVA	Magic Valley Hatchery
MCCA	McCall Hatchery
MCKE	McKenzie Hatchery
METH	Methow Hatchery
MONT	Montlake Hatchery
NCHH	Naches Hatchery
NISP	Niagara Springs Hatchery
NPTH	Nez Perce Tribal Hatchery
OASP	Oak Springs Hatchery
OXBO	Oxbow Hatchery (IDFG)
PAHH	Pahsimeroi Hatchery
POWP	Powell Rearing Pond
PRDH	Priest Rapids Hatchery
RAPH	Rapid River Hatchery
REDP	Red River Rearing Pond
RINH	Ringold Hatchery

Code	Hatchery
ROAR	Roaring River Hatchery
ROBU	Round Butte Hatchery
RRHH	Rocky Reach Hatchery
SAND	Sandy Hatchery
SAWT	Sawtooth Hatchery
SERH	Sea Resources Hatchery (Chinook River, WA)
SIMP	Similkameen Pond/Hatchery
SKAM	Skamania Hatchery
SOSA	South Santiam Hatchery
SPEE	Speelyai Hatchery
SPRC	Spring Creek NFH
SWSP	Sweetwater Springs Hatchery
TOUT	Toutle Hatchery

Code	Hatchery
TRAS	Trask Hatchery
TUCH	Tucannon Hatchery
TURO	Turtle Rock Hatchery
UMAH	Umatilla Hatchery
VANC	Vancouver Hatchery
WAHA	Washougal Hatchery
WALH	Wallowa Hatchery
WELH	Wells Hatchery
WILH	Willamette Hatchery
WILL	Willard NFH
WINT	Winthrop NFH
WSPH	Warm Springs NFH
YAKH	Yakima Hatchery
	No Hatchery Specified

G. Capture Method Codes

Code	Capture Method
BPRCOL	Bypass Facility Raceway Collection
BPSUB	Bypass Sub-Sample
BSEINE	Beach Seine
BTRAP	Box Trap
CMTRAP	Cray-Meeken Trap
CREEL	Sport Fishery
DIPNET	Dip Net
DIPTRP	Dipper Trap
DIVSYS	Diversion System
FYKNET	Fyke Net
GILNET	Commercial or Tribal Gillnet Fishery
GWAIRL	Gatewell Airlift
GWDIP	Gatewell Dip Net
GWFYKE	Gatewell Fyke Net
HATCH	Hatchery Returns
HATRAK	Hatchery Rack
HOOK	Hook and Line
LADDER	Adult Passage Ladder
MTRAP	Minnow Trap
NONE	Not Applicable
PRED	Predation Mark Recovery
PSEINE	Purse Seine
SCOTRP	Scoop Trap
SCREWT	Screw Trap
SHOCK	Electro-Shock
SURVEY	Spawning Survey
TRAWL	Trawl Net
TROLL	Ocean Troll Fishery
WTRAP	Weir Trap

H. Tagging Method Codes

CODE	TAGGING METHOD
AUTO	Auto Tagger
GAST	Gastric Implantation
HAND	Hand-Held Syringe
NONE	None
SURG	Surgically Implanted

I. Organization Codes

Code	Organization
BIOMRK	Biomark
COE	U.S. Army Corps of Engineers
CPUD	Chelan County Public Utility District
CRITFC	Columbia River Inter-Tribal Fish Commission
CTUIR	Confed. Tribes of the Umatilla Indian Reser.
DUCKSU	Ducks Unlimited
FPC	Fish Passage Center
ICFWRU	Idaho Cooperative F&W Research Unit
IDFG	Idaho Dept. of Fish and Game
NMFS	NOAA Fisheries
NPT	Nez Perce Tribe
ODFW	Oregon Dept. of Fish and Wildlife
PGE	Portland General Electric
PNL	Pacific Northwest Labs (Battelle)
PNW	U.S. Dept. of Agriculture
PSMFC	Pacific States Marine Fisheries Commission
SEARES	Sea Resources
SHOBAN	Shoshone-Bannock Tribes
UCFWRU	Utah Cooperative F&W Research Unit
USFWS	U.S. Fish and Wildlife Service
USGS	U.S. Geological Survey
WDF	Washington Dept. of Fish (archaic)
WDFW	Washington Dept. of Fish and Wildlife
WDW	Washington Dept. of Wildlife (archaic)
YINN	Yakama Nation

J. Tag and Release Site Codes

1. Site Codes

The site code is an abbreviated description (four to six characters) of the tagging and/or release location. A site descriptor, if present, will be found in the last one to three characters. For all site codes that replicate an already established code, a number (2 through 9) will immediately proceed the site descriptor. For example:

ELKC: Elk Creek	ELK2C: A second Elk Creek	ELK3C: A third Elk Creek

Rivers and streams that extend through two or more USGS Hydrologic Units are assigned specific River Reach codes for each corresponding Hydrologic Unit Code (HUC). The River Reach codes terminate in a single-digit integer starting with '1' (corresponding with the mouth of the river or stream, and incrementing to the maximum number of distinct HUCs. For example, the Columbia River passes through nine HUCs between its mouth and Chief Joseph Dam (blocking anadromous fish passage), and thus there are nine Columbia River Reach codes (COLR1 – COLR9).

The following are valid site descriptors:

B: Bridge	C: Creek	CH: Channel
CN: Canal	D: Dam	FK: fork of a river, but not part of a name (e.g., Salmon River, East Fork, but not Brushy Fork Creek)
I or IS: Island	P: Pond	
R: River	S: Screen	
SL: Slough	T or TRP: Trap	W: Weir

2. River Kilometer Code

The river kilometer code uses a hierarchical coding scheme: kilometers from the mouth of the Columbia to the Release site (up to 7th order stream for point release sites), with each tributary delimited with a period (e.g., the code for the location of the Lower Granite Dam is 522.173 = 522 km from the mouth of the Columbia to the mouth of the Snake, and 173 km from the mouth of the Snake to the dam). Each segment of the code is three characters long, zero-padded from the left. If additional sites are required, contact your PIT Tag Steering Committee member to add your requests to the list. River kilometer codes have a minimum length of three characters and a maximum length of 27 characters; the domain of characters is generally limited to integers and the period. There is an exception for the OCEAN code (“~”), and landlocked site definitions (such as Potholes Reservoir) that use the “_” code to indicate a “landlocked” location. When kilometers are calculated from measurements in miles, a standard conversion of 0.6214 m/km is used and the result is rounded to the nearest integer.

When releasing or recovering fish in-river (as opposed to releasing or recovering at one of the listed fixed-site locations), the distance upstream from the mouth of the river, stream, or creek, is appended (in kilometers) to the base river kilometer code for that river.

For example, a project that is tagging 10 kilometers above the mouth of the Salmon River, South Fork would be identified as:

SALRSF 522.303.215.010

3. GIS Hydrounits

See Appendix B for a more formal treatment of this topic. The USGS Hydrologic Unit Code (HUC) is an eight-digit number, comprised of four two-digit fields, used to identify part or all of a surface drainage basin. In the Pacific Northwest, these are generally the same sub-basins or “provinces”, identified in the Northwest Power and Conservation Council’s Fish & Wildlife Program. Each tagging, release, recapture, or mortality site listed in tables IV.5a-b is located within a specific HUC.

4. Point Release Sites vs. Fixed Release Sites

In the following two tables, the indicator column labeled "I" contains a "Y" or an "N". This indicator specifies "Y" if the associated Tagging or Release Site is a "Point Release Site", or an "N" otherwise.

A point release site cannot be modified with an additional suffix or segment. Examples of point release sites are dams, weirs, traps, bridges, etc. For release locations upstream from the point release sites,

find the code for the confluence of the first stream down from the point release site and then append the suffix you need to that river kilometer value.

5. Mark and Recapture Site Codes

The valid site codes for tag, release, recapture, and mortality events are listed in the tables below, sorted by either "Site Code" or "River KM".

1. Mark and Recapture Site Codes By Site Code

Mark and Recapture Site Codes By Site Code					
Site Code	Location Name	I	River KM	Total RKM	Hydro Unit
3LINKC	Three Links Creek	N	522.224.120.037.051	954	17060302
3MILIS	Three Mile Canyon Island (Col. R. below Blalock Island)	Y	412	412	17070101
4JULYC	Fourth of July Creek	N	522.303.630	1455	17060201
ABEH	Abernathy SCTC	Y	087.005	92	17080003
ABERC	Abernathy Creek, Lower Columbia River, Washington	N	087	87	17080003
AHTANC	Ahtanum Creek, Yakima River	N	539.172	711	17030003
ALTULC	Alturas Lake Creek	N	522.303.633	1458	17060201
ALTURL	Alturas Lake	Y	522.303.633.011	1469	17060201
AMERR	American River	N	522.224.120.101	967	17060305
BADGEI	Badger Island, Columbia River	Y	512	512	17070101
BARGAC	Bargamin Creek	N	522.303.255	1080	17060207
BBC	Big Beef Creek	N	*	0	17110018
BCANF	Big Canyon Facility	Y	522.271.131.018.001	943	17060105
BCCAP	Big Canyon Creek Acclimation Facility (Clearwater River)	Y	522.224.057	803	17060306
BCKROC	Buckaroo Creek	N	465.117	581	17070103
BCTRAP	Lake Washington, Bear Creek Trap	Y	***	0	17110012
BEARC	Bear Creek	N	522.224.120.037.081	984	17060301
BEARVC	Bear Valley Creek	N	522.303.319.170	1314	17060205
BEAVEC	Beaver Creek	N	522.303.642	1467	17060201
BEDRKC	Bedrock Creek	N	522.224.042	788	17060306
BIG2C	Big Creek, Middle Fork Salmon River	N	522.303.319.029	1173	17060206
BIGC	Big Creek Hatchery (ODFW) near Knappa	N	043.006	49	17080006
BIGCAC	Big Canyon Creek	N	522.224.057	803	17060306
BIGFLC	Big Flat Creek	N	522.224.120.037.113.026	1042	17060303
BIGMAC	Big Mallard Creek	N	522.303.247	1072	17060207
BIGWSP	Big White Salmon Ponds	Y	271.002	273	17070105
BIRCHC	Birch Creek	N	465.077	541	17070103
BIRCHE	East Fork Birch Creek	N	465.077.026	567	17070103
BIRCHW	West Fork Birch Creek	N	465.077.026	567	17070103
BLNDSL	Blind Slough Net Pens (Oregon side of Columbia River Estuary)	Y	047	47	17080006
BO1	Bonneville Dam PH1 (Archaic - replaced with generic BON designation)	N	*	0	17070105
BO2	Bonneville Dam PH2 (Archaic - replaced with generic BON designation)	N	*	0	17070105
BON	Bonneville Dam Complex	N	*	0	17070105
BONH	Bonneville Hatchery	Y	232.001	233	17080001

Mark and Recapture Site Codes By Site Code					
Site Code	Location Name	I	River KM	Total RKM	Hydro Unit
BONP	Bonifer Springs Acclimation Pond	Y	465.127.003	595	17070103
BOSTCC	Boston Canyon Creek	N	465.127.003	594	17070103
BOULDC	Boulder Creek	N	522.224.120.037.042	945	17060303
BOUNDC	Boundary Creek	N	522.303.319.154	1298	17060205
BOUTRP	Boulder Creek Trap	Y	522.224.120.037.042.001	946	17060303
BRUSHC	Brushy Fork Creek	N	522.224.120.037.113.011	1027	17060303
BSHEEC	Big Sheep Creek	N	522.308.032	862	17060102
BUCKC	Buck Creek	N	465.145.002	611	17070103
BURNLC	Burnt Log Creek	N	522.303.215.060.024.024	1148	17060208
BUTCHC	Butcher Creek	N	465.127.034	625	17070103
CAMASC	Camas Creek, Middle Fork Salmon River	N	522.303.319.057	1201	17060206
CAMPC	Camp Creek	N	465.127.018	609	17070103
CANYOC	Canyon Creek	N	522.224.120.037.012	915	17060303
CAPEHC	Capehorn Creek	N	522.303.319.170.010	1324	17060205
CARP	Carlton Acclimation Pond	Y	843.058	902	17020008
CARS	Carson National Fish Hatchery	Y	251.028	279	17070105
CASS	Cassimer Bar Hatchery	N	*	0	17020006
CATCMF	Middle Fork Catherine Creek	N	522.271.232.052.005	1082	17060104
CATCNF	North Fork Catherine Creek	N	522.271.232.052	1077	17060104
CATCSF	South Fork Catherine Creek	N	522.271.232.052	1077	17060104
CATHEC	Catherine Creek	N	522.271.232	1025	17060104
CATHEP	Catherine Creek Pond	Y	522.271.232.048	1073	17060104
CATHEW	Catherine Creek Weir	Y	522.271.232.032	1057	17060104
CEDARC	Cedar Creek, tributary to Lewis River	N	140.025	165	17080002
CFCTRP	Crooked Fork Creek Trap	Y	522.224.120.037.113.003	1019	17060303
CHAMBC	Chamberlain Creek	N	522.303.282	1107	17060207
CHAMPC	Champion Creek	N	522.303.631	1456	17060201
CHAMWF	West Fork Chamberlain Creek	N	522.303.282.024	1131	17060207
CHANDL	Chandler Canal	N	539.076	615	17030003
CHEL	Chelan PUD Hatchery	N	*	0	17020010
CHEWUP	Chewuch Acclimation Pond (WDFW)	Y	843.080.010	933	17020008
CHEWUR	Chewuch River	N	843.080	923	17020008
CHINOR	Chinook River, Washington (Columbia River Estuary)	N	006	6	17080006
CHIP	Chiwawa Rearing Pond	Y	754.077.002	833	17020011
CHIWAR	Chiwawa River	N	754.077	831	17020011
CHIWAT	Chiwawa River Trap, 0.5 km below CHIP acclimation pond	Y	754.077.002	833	17020011
CJRAP	Captain John Rapids Acclimation Pond	Y	522.263	785	17060103
CLARFP	Clark Flat Acclimation Pond	Y	539.270	809	17030001
CLEARC	Clear Creek	N	522.224.120.004	870	17060304
CLEE	Cle Elum Hatchery	Y	539.293	832	17030001
CLELMD	Cle Elum Dam	Y	539.299.013	851	17030001
CLELMR	Cle Elum River	N	539.299	838	17030001
CLWH	Clearwater Hatchery	N	*	0	17060306
CLWR	Clearwater River	N	522.224	746	17060306
CLWRMF	Middle Fork Clearwater River	N	522.224.120	866	17060304
CLWRNF	North Fork Clearwater River	N	522.224.065	811	17060308
CLWRSF	South Fork Clearwater River	N	522.224.120	866	17060305

Mark and Recapture Site Codes By Site Code					
Site Code	Location Name	I	River KM	Total RKM	Hydro Unit
CLWTRP	Clearwater Trap	Y	522.224.010	756	17060306
COLR	Columbia River (Archaic - replaced with reach-specific definitions)	N	000	0	170*
COLR1	Columbia River - mouth to Three Tree Point, WA (km 0-49)	N	000	0	17080006
COLR2	Columbia River - Three Tree Point, WA to Lewis River (km 49-140)	N	000	0	17080003
COLR3	Columbia River - Lewis River to Bonneville Dam (km 140-234)	N	000	0	17080001
COLR4	Columbia River - Bonneville Dam to John Day Dam (km 234-347)	N	000	0	17070105
COLR5	Columbia River - John Day Dam to Snake River (km 347-522)	N	000	0	17070101
COLR6	Columbia River - Snake River to Lower Crab Creek (km 522-661)	N	000	0	17020016
COLR7	Columbia River - Lower Crab Creek to Chelan Falls, WA (km 661-809)	N	000	0	17020010
COLR8	Columbia River - Chelan Falls, WA to Grand Coulee Dam (km 809-960)	N	000	0	17020005
COLTC	Colt Creek	N	522.224.120.037.113.020	1036	17060303
COLTKC	Colt Kill Creek - Replaces WHITSC	N	522.224.120.037.113	1016	17060303
COONSC	Coonskin Creek	N	465.109	573	17070103
COTNWC	Cottonwood Creek	N	522.224.031	777	17060306
COTP	Cottonwood Acclimation Pond	Y	522.271.046	839	17060106
COTTWC	Cottonwood Creek (Umatilla River)	N	465.105	569	17070103
COWLR1	Cowlitz River - mouth to Crispus River (km 0-145)	N	111	111	17080005
COWLR2	Cowlitz River - Crispus River to headwaters (km 145-216)	N	111	111	17080004
COWS	Cowlitz Salmon Hatchery	Y	111.080	191	17080005
COWT	Cowlitz Trout Hatchery	Y	111.071	182	17080005
COYOTC	Coyote Creek	N	465.145.005	614	17070103
CRESIS	Crescent Island, Columbia River	Y	510	510	17070101
CROOC	Crooked Creek	N	522.303.200	1025	17060207
CROOKC	Crooked Fork Creek	N	522.224.120.037.113	1016	17060303
CROOKP	Crooked River Pond	Y	522.224.120.094.015	975	17060305
CROOKR	Crooked River	N	522.224.120.094	960	17060305
CROTRP	Crooked River Trap	Y	522.224.120.094.001	961	17060305
CRTRAP	Lake Washington, Cedar River Trap	Y	***	0	17110012
CUNNSL	Cunningham Slough	N	139.000	139	17090012
CURP	Curl Lake Rearing Pond	Y	522.100.066	701	17060107
DAGGEC	Dagger Creek	N	522.303.319.155	1299	17060205
DAYP	Dayton Acclimation Pond	Y	509.035.087	631	17070102
DEADMC	Deadman Creek	N	522.224.120.037.016	919	17060303
DECKEC	Decker Creek	N	522.303.624.001	1450	17060201
DESCH1	Deschutes River - mouth to Round Butte Dam (0-178 km)	N	328	328	17070306
DRNP	Deep River Net Pens (Deep River, Washington)	Y	035.002	37	17080006
DRYP	Dryden Acclimation Pond	Y	754.026	780	17020011

Mark and Recapture Site Codes By Site Code					
Site Code	Location Name	I	River KM	Total RKM	Hydro Unit
DWOR	Dworshak National Fish Hatchery	Y	522.224.065	811	17060306
DWORMS	Dworshak NFH, release into mainstem Clearwater River	Y	522.224.065	811	17060306
DWORNF	Dworshak NFH, release into North Fork Clearwater River	Y	522.224.065.000	811	17060308
EAGH	Eagle Creek National Fish Hatchery, in Clackamas River Basin	Y	163.040.027.016	246	17090011
EAGL	Eagle Hatchery	N	*	0	17050114
EAGLEC	Eagle Creek	N	522.224.120.037.253.003	1159	17060301
EASTOP	Easton Acclimation Pond	Y	539.325	864	17030001
EBNK	East Bank Hatchery	N	*	0	17020010
ELDORC	Eldorado Creek	N	522.224.087.041	874	17060306
ELKC	Elk Creek	N	522.303.319.170.014	1328	17060205
ELRH	Elochoman River Hatchery (Elochoman River, Washington)	Y	058.019	77	17080003
ENTH	Entiat NFH	Y	778.017	795	17020010
ENTIAR	Entiat River	N	778	778	17020010
ESANIS	East Sand Island, Columbia River	Y	008	8	17080006
FALLC	Fall Creek	N	522.303.319.163	1307	17060205
FISHC	Fish Creek	N	522.224.120.037.039	942	17060303
FISHEC	Fisher Creek	N	522.303.628	1453	17060201
FISTRP	Fish Creek Trap	Y	522.224.120.037.039.002	944	17060303
FIVEMC	Five Mile Creek	N	522.224.120.094.018	978	17060305
FLOSSC	Flossie Creek	N	522.303.282.027	1134	17060207
FOUNDI	Foundation Island, Columbia River	Y	518	518	17070101
FRENC	Frenchman Creek	N	522.303.647	1472	17060201
FRENCH	French Creek	N	522.303.169	994	17060209
GEDCWF	West Fork Gedney Creek	N	522.224.120.037.029.005	937	17060302
GEDNEC	Gedney Creek	N	522.224.120.037.029	932	17060302
GOLDC	Gold Creek	N	522.303.621	1446	17060201
GRAND1	Grande Ronde River - mouth to Wallowa River (km 0-131)	N	522.271	793	17060106
GRAND2	Grande Ronde River - Wallowa River to headwaters (km 131-325)	N	522.271	793	17060104
GRANDP	Grande Ronde River Pond	Y	522.271.320	1113	17060104
GRANDR	Grande Ronde River (Archaic - replaced with reach-specific definitions)	N	522.271	793	170601*
GRANDW	Grande Ronde River Weir	Y	522.271.307	1100	17060104
GRNTRP	Grande Ronde River Trap	Y	522.271.002	795	17060106
HAGE	Hagerman NFH	N	*	0	17040212
HARDC	Hard Creek	N	522.303.140.031.002	698	17060210
HAZARC	Hazard Creek	N	522.303.140.031	996	17060210
HCD	Hells Canyon Dam	N	522.397	919	17060101
HELLRC	Hell Roaring Creek	N	522.303.631	1456	17060201
HERDC	Herd Creek	N	522.303.552.014	1391	17060201
HORSEC	Horse Creek	N	522.303.301	1126	17060207
HUCKLC	Huckleberry Creek	N	522.303.624	1449	17060201
HUNGC	Hungry Creek (Lochsa River Basin)	N	522.224.120.037.039.007	949	17060303
I-90B	I-90 bridge over Columbia River	Y	677	677	17020010

Mark and Recapture Site Codes By Site Code					
Site Code	Location Name	I	River KM	Total RKM	Hydro Unit
	upstream of Wannapum Dam				
ICICLC	Icicle Creek	N	754.041	795	17020011
ICTRAP	Lake Washington, Issaquah Creek Trap	Y	***	0	17110012
IHR	Ice Harbor Dam	N	*	0	17060110
IMNAHR	Imnaha River	N	522.308	830	17060102
IMNAHW	Imnaha River Weir	Y	522.308.074	904	17060102
IMNTRP	Imnaha Trap	Y	522.308.007	837	17060102
IMQP	Imeques Acclimation Pond	Y	465.123	588	17070103
INDIAC	Indian Creek, Middle Fork Salmon River	N	522.303.319.110	1254	17060205
IRRI	Irrigon Hatchery	N	*	0	17070101
IS18	Island 18, Columbia River	Y	549	549	17020016
JACKCP	Jack Creek Acclimation Pond	Y	539.284.017.009	849	17030001
JACKSC	Jacks Creek	N	522.224.047	793	17060306
JDA	John Day Dam	N	*	0	17070105
JDAR	John Day River (Archaic - replaced with reach-specific definitions)	N	351	351	170702*
JDAR1	John Day River - mouth to North Fork John Day River (km 0-298)	N	351	351	17070204
JDAR2	John Day River - North Fork John Day River to headwaters (km 298-454)	N	351	351	17070201
JDARMF	Middle Fork John Day River	N	351.298.052	701	17070203
JDARNF	North Fork John Day River	N	351.298	649	17070202
JDARSF	South Fork John Day River	N	351.341	692	17070201
JERSEC	Jersey Creek	N	522.303.223	1048	17060207
JOHNC	Johns Creek	N	522.224.120.056	922	17060305
JOHNSC	Johnson Creek	N	522.303.215.060.024	1124	17060208
JOHTRP	Johnson Creek Trap	Y	522.303.215.060.024.007	1131	17060208
JSFBC	Black Canyon Creek, South Fork John Day River	N	351.341.023	715	17070201
JSFDC	Deer Creek, South Fork John Day River	N	351.341.028	720	17070201
JSFMC	Murderers Creek, South Fork John Day River	N	351.341.027	719	17070201
JSFWC	Wind Creek, South Fork John Day River	N	351.341.033	725	17070201
KNAPPC	Knapp Creek	N	522.303.319.170.015	1329	17060205
KNOXB	Knox Bridge	Y	522.303.215.112	1152	17060208
KOOS	Kooskia National Fish Hatchery	Y	522.224.120.004.001	871	17060304
LAKEC	Lake Creek	N	522.303.215.059.045	1144	17060208
LAPC	Lapwai Creek	N	522.224.019	765	17060306
LCATHC	Little Catherine Creek	N	522.271.232.044	1069	17060104
LEA	Leaburg Dam	N	*	0	17090004
LEAB	Leaburg Hatchery	Y	163.282.056	501	17090004
LEAV	Leavenworth National Fish Hatchery	Y	754.041.005	800	17020011
LEMHIR	Lemhi River	N	522.303.416	1241	17060204
LEMHIW	Lemhi River Weir	Y	522.303.416.049	1290	17060204
LEWISR	Lewis River	N	140	140	17080002
LGR	Lower Granite Dam	N	*	0	17060107
LGS	Little Goose Dam	N	*	0	17060107

Mark and Recapture Site Codes By Site Code					
Site Code	Location Name	I	River KM	Total RKM	Hydro Unit
LICKC	Lick Creek	N	522.303.215.059.008	1107	17060208
LINEC	Line Creek	N	465.127.008	599	17070103
LITCAC	Little Canyon Creek	N	522.224.057.005	808	17060306
LITNGC	Lightning Creek - Imnaha River	N	522.308.008	838	17060102
LMEMIS	Little Memaloose Island, Columbia River	Y	314	314	17070105
LMILIS	Little Miller Island, Columbia River	Y	331	331	17070105
LMN	Lower Monumental Dam	N	*	0	17060110
LNSANR	Little North Santiam River	N	163.174.019.044	400	17090005
LOCHSA	Lochsa River	N	522.224.120.037	903	17060303
LOLOC	Lolo Creek	N	522.224.087	833	17060306
LOOH	Lookingglass Hatchery	Y	522.271.137.003	933	17060104
LOOKGC	Lookingglass Creek	N	522.271.137	930	17060104
LOONC	Loon Creek	N	522.303.319.073	1217	17060205
LOSTIP	Lostine River Pond	Y	522.271.131.042.021	987	17060105
LOSTIR	Lostine River	N	522.271.131.042	966	17060105
LOSTIW	Lostine River Weir	Y	522.271.131.042.001	967	17060105
LSALR	Little Salmon River	N	522.303.140	965	17060210
LSFTRP	Lower South Fork Salmon River Trap	N	522.303.215	1040	17060208
LSHEEF	Little Sheep Facility	Y	522.308.032.005.008	875	17060102
LUNION	Lake Union	Y	***	0	17110012
LWBEAR	Bear Creek, Lake Washington below Remond Way Bridge	Y	***	0	17110012
LWCEDR	Cedar River, Lake Washington at Logan Street Bridge	Y	***	0	17110012
LWISSQ	Lake Washington, Issaquah Creek at SE 56th Street Bridge	Y	***	0	17110012
LWSCCL	Ballard Locks	Y	***	0	17110012
LWSCFC	Ship Canal, Lake Washington at Fremont Cut/Bridge	Y	***	0	17110012
LWSCMC	Ship Canal, Lake Washington at Montlake Cut/Bridge	Y	***	0	17110012
LWSCML	Ship Canal, Lake Washington at King County/Metro Environmental Lab	Y	***	0	17110012
LWSH	Little White Salmon National Fish Hatchery	Y	261.002	263	17070105
LYFE	Lyons Ferry Hatchery	Y	522.095	617	17060107
MARSHC	Marsh Creek	N	522.303.319.170	1314	17060205
MARTRP	Marsh Creek Trap	Y	522.303.319.170.011	1325	17060205
MAVA	Magic Valley Hatchery	N	*	0	17040212
MAYD	Mayfield Dam	Y	111.085	196	17080005
MAYSC	Mays Creek	N	522.303.631	1456	17060201
MCCA	McCall Hatchery	N	*	0	17050123
MCKAYC	McKay Creek	N	465.082	546	17070103
MCKE	McKenzie Hatchery	Y	163.282.053	498	17090004
MCKER	McKenzie River	N	163.282	445	17090004
MCN	McNary Dam	N	*	0	17070101
MEACHC	Meacham Creek	N	465.127	591	17070103
MEACHE	East Fork Meacham Creek	N	465.127.031	622	17070103
MEACHN	North Fork Meacham Creek	N	465.127.024	615	17070103

Mark and Recapture Site Codes By Site Code					
Site Code	Location Name	I	River KM	Total RKM	Hydro Unit
MEAD2C	Meadow Creek, South Fork Clearwater	N	522.224.120.053	919	17060305
MEADOC	Meadow Creek, Selway River	N	522.224.120.037.031	934	17060302
METH	Methow Hatchery	Y	843.085	928	17020008
METHR	Methow River	N	843	843	17020008
METRO	King County/Metro Environmental Lab	Y	***	0	17110012
MILLC	Mill Creek, Walla Walla River	N	509.054	563	17070102
MINAMR	Minam River	N	522.271.131.016	940	17060105
MINKC	Mink Creek	N	522.224.120.037.051	954	17060302
MINP	Minthorn Acclimation Pond	Y	465.109	574	17070103
MISSC	Mission Creek	N	522.224.019.016	781	17060306
MISSNC	Mission Creek (Umatilla River)	N	465.098	562	17070103
MONT	Montlake Hatchery	N	*	0	17110012
MOONSC	Moonshine Creek	N	465.108	572	17070103
MOOS2C	Moose Creek (Selway River)	N	522.224.120.037.065	968	17060302
MOOS2N	North Fork Moose Creek, Selway River	N	522.224.120.037.065.006	974	17060302
MOOSEC	Moose Creek	N	522.303.282.031	1138	17060207
MULTCH	Multnomah Channel, Columbia River	N	139	139	17090012
NASONC	Nason Creek (tributary to Wenatchee River)	N	754.089	843	17020011
NATCHR	Natches River	N	539.187	726	17030002
NEWSOC	Newsome Creek	N	522.224.120.084	950	17060305
NISP	Niagara Springs Hatchery	N	*	0	17040212
NLVP	North Lapwai Valley Acclimation Pond	Y	522.224.019.001	766	17060306
NONE	Deprecated null value used only to support legacy data.	N	*	0	99999999
NPTH	Nez Perce Tribal Hatchery	Y	522.224.038	784	17060306
NSANTR	North Santiam River, Oregon	N	163.174.019	356	17090005
OCEAN	Ocean Recovery	Y	~~~	0	N/A
OHARAC	O'Hara Creek	N	522.224.120.037.012	915	17060302
OKANR	Okanogan River	N	858	858	17020006
OLDMAC	Old Man Creek	N	522.224.120.037.028	931	17060303
OMAKC	Omak Creek (tributary to Okanogan River)	N	858.064	922	17020006
OROFC	Orofino Creek	N	522.224.072	818	17060306
OSOL	Osoyoos Lake	Y	858.130	988	17020006
OXBO	Oxbow Hatchery (IDFG)	N	*	0	17050201
PAHP	Pahsimeroi Pond	N	522.303.489.011	1325	17060202
PAHSIR	Pahsimeroi River	N	522.303.489	1314	17060202
PAHSIW	Pahsimeroi Weir	Y	522.303.489.002	1316	17060202
PAHTRP	Pahsimeroi River Trap	Y	522.303.489.002	1316	17060202
PANT2C	Panther Creek (trib. to Wind River, Wash.)	N	251.007	258	17070105
PANTHC	Panther Creek (Salmon River)	N	522.303.338	1163	17060203
PAPOOC	Papoose Creek	N	522.224.120.037.105	1008	17060303
PARTRC	Partridge Creek	N	522.303.160	985	17060209
PEARSC	Pearson Creek	N	465.077.026.018	585	17070103
PELTON	Pelton Ladder	Y	328.161	489	17070306
PENP	Pendleton Acclimation Pond	Y	465.090	555	17070103
PESHAR	Peshastin River	N	754.029	783	17020011
PETEKC	Pete King Creek	N	522.224.120.037.003	906	17060303

Mark and Recapture Site Codes By Site Code					
Site Code	Location Name	I	River KM	Total RKM	Hydro Unit
PETTL	Pettit Lake	Y	522.303.633.002.002	1462	17060201
PETTL	Pettit Lake Creek	N	522.303.633.002	1460	17060201
PISTOC	Pistol Creek, Middle Fork Salmon River	N	522.303.319.118	1262	17060205
PLAP	Pittsburg Landing Acclimation Facility	Y	522.346	868	17060101
POLEC	Pole Creek	N	522.303.642	1467	17060201
POSTOC	Post Office Creek	N	522.224.120.037.082	985	17060303
POTHOL	Potholes Reservoir, Grant County, Washington	Y	—	0	17020015
POTR	Potlatch River	N	522.224.024	770	17060306
POWP	Powell Rearing Pond	Y	522.224.120.037.113	1016	17060303
PRD	Priest Rapids Dam	N	639	639	17020016
PRDH	Priest Rapids Hatchery	Y	639	639	17020016
PROSRD	Prosser Dam	Y	539.076	615	17030003
PROTRP	Prosser Trap	Y	539.076	617	17030003
RAPH	Rapid River Hatchery	Y	522.303.140.007.006	978	17060210
RAPIDR	Rapid River, Little Salmon River	N	522.303.140.007	972	17060210
RAPIWF	West Fork Rapid River	N	522.303.140.007.012	984	17060210
RAPR	Rapid River, Middle Fork Salmon River	N	522.303.319.124	1268	17060205
RATTL	Rattlesnake Creek	N	271.012	283	17070105
REDFL	Redfish Lake	Y	522.303.615.005	1445	17060201
REDFLC	Redfish Lake Creek	N	522.303.615	1440	17060201
REDP	Red River Rearing Pond	N	522.224.120.101.027	994	17060305
REDR	Red River	N	522.224.120.101	967	17060305
REDRSF	South Fork Red River	N	522.224.120.101.028	995	17060305
REDTRP	Red River Trap	Y	522.224.120.101.006	973	17060305
RELIEC	Relief Creek	N	522.224.120.094.013	973	17060305
RICEIS	Rice Island	Y	034	34	17080006
RICHIS	Richland Island, Columbia River	Y	545	545	17020016
RINH	Ringold Hatchery	Y	567	567	17020016
RIS	Rock Island Dam	N	*	0	17020010
RLCTR	Redfish Lake Creek Trap	Y	522.303.615.003	1443	17060201
ROSAD	Rosa Dam	Y	539.206	745	17030001
RPDTR	Rapid River Trap	Y	522.303.140.007.007	979	17060210
RRE	Rocky Reach Dam	N	*	0	17020010
RUNNIC	Running Creek	N	522.224.120.037.253	1156	17060301
RUSHC	Rush Creek, tributary of Big Creek, Middle Fork Salmon River	N	522.303.319.029.011	1184	17060206
RYANC	Ryan Creek	N	465.132	596	17070103
SABEC	Sabe Creek	N	522.303.272	1097	17060207
SAEFSF	East Fork South Fork Salmon River	N	522.303.215.060	1100	17060208
SALEFT	East Fork Salmon River Trap	Y	522.303.552.029	1406	17060201
SALEFW	East Fork Salmon River Weir	Y	522.303.552.030	1407	17060201
SALMF1	Middle Fork Salmon River - mouth to Loon Creek (km 0-73)	N	522.303.319	1144	17060206
SALMF2	Middle Fork Salmon River - Loon Creek to headwaters (km 73-170)	N	522.303.319	1144	17060205
SALMOC	Salmon Creek (tributary to Okanogan River)	N	858.055	913	17020006

Mark and Recapture Site Codes By Site Code					
Site Code	Location Name	I	River KM	Total RKM	Hydro Unit
SALR	Salmon River (Archaic - replaced with reach-specific definitions)	N	522.303	825	170602*
SALR1	Salmon River - mouth to above French Creek (km 0-171)	N	522.303	825	17060209
SALR2	Salmon River - above French Creek to Middle Fork Salmon River (km 171-319)	N	522.303	825	17060207
SALR3	Salmon River - Middle Fork Salmon River to Pahsimeroi River (km 319-489)	N	522.303	825	17060203
SALR4	Salmon River - Pahsimeroi River to headwaters (km 489-650)	N	522.303	825	17060201
SALREF	East Fork Salmon River	N	522.303.552	1377	17060201
SALRMF	Middle Fork Salmon River	N	522.303.319	1144	17060206
SALRNF	North Fork Salmon River	N	522.303.381	1206	17060203
SALRSF	South Fork Salmon River	N	522.303.215	1040	17060208
SALSFW	South Fork Salmon River Weir	Y	522.303.215.111	1151	17060208
SALTRP	Salmon Trap	Y	522.303.103	910	17060209
SANTIR	Santiam River, Oregon	N	163.174	337	17090005
SATUSC	Satus Creek, Yakima River	N	539.112	651	17030003
SAWT	Sawtooth Hatchery	Y	522.303.617	1442	17060201
SAWTRP	Sawtooth Trap	Y	522.303.617	1442	17060201
SECESR	Secesh River	N	522.303.215.059	1099	17060208
SELWY1	Selway River - mouth to Moose Creek (km 0-65)	N	522.224.120.037	903	17060302
SELWY2	Selway River - Moose Creek to headwaters (km 65-147)	N	522.224.120.037	903	17060301
SELWYR	Selway River	N	522.224.120.037	903	17060302
SERH	Sea Resources Hatchery (Chinook River, Washington)	Y	006.006	12	17080006
SFSTRP	South Fork Salmon River Trap	Y	522.303.215.115	1155	17060208
SHEEPC	Sheep Creek	N	522.303.188	1013	17060207
SHEPC	Sheep Creek, Middle Fork Salmon River	N	522.303.319.049	1193	17060206
SHIMC	Shimmihorn Creek	N	465.145.008	617	17070103
SIMILP	Similkameen Acclimation Pond (replaces archaic SIMP)	Y	858.119.008	985	17020007
SIMILR	Similkameen River	N	858.119	977	17020007
SIMP	Similkameen Pond (Archaic - Replaced by SIMILP)	N	941.121.008	1070	17020007
SLATEC	Slate Creek	N	522.303.106	931	17060209
SMILEC	Smiley Creek	N	522.303.644	1469	17060201
SNAKE1	Snake River - mouth to Palouse River (km 0-96)	N	522	522	17060110
SNAKE2	Snake River - Palouse River to Clearwater River (km 96-224)	N	522	522	17060107
SNAKE3	Snake River - Clearwater River to Salmon River (km 224-303)	N	522	522	17060103
SNAKE4	Snake River - Salmon River to Hells Canyon Dam (km 303-397)	N	522	522	17060101

Mark and Recapture Site Codes By Site Code					
Site Code	Location Name	I	River KM	Total RKM	Hydro Unit
SNAKER	Snake River (Archaic - replaced with reach-specific definitions)	N	522	522	170601*
SNKTRP	Snake Trap	Y	522.225	747	17060103
SPRC	Spring Creek National Fish Hatchery	Y	269	269	17070105
SQAWC	Squaw Creek (Umatilla River)	N	465.124	588	17070103
SQUAWC	Squaw Creek	N	522.224.120.037.096	999	17060303
SQUAWP	Squaw Creek Acclimation Pond	Y	522.303.564.001	1390	17060201
SSANTR	South Santiam River, Oregon	N	163.174.019	356	17090006
SSD	Sunnyside Dam	N	539.167	706	17030003
SSIDEC	Sunnyside Canal	N	539.167	706	17030003
SSIDES	Sunnyside Screen	Y	539.167.001	707	17030003
STANLC	Stanley Lake Creek	N	522.303.609.009	1443	17060201
STANLE	Stanley (Gage 2945)	Y	522.303.609	1434	17060201
STOLP	Stolle Pond	Y	522.303.215.125	1165	17060208
STORMC	Storm Creek	N	522.224.120.037.113.016	1032	17060303
SUL	Sullivan Dam	N	163.043	206	17090012
SULFUC	Sulphur Creek, Middle Fork Salmon River	N	522.303.319.150	1294	17060205
SWSP	Sweetwater Springs Hatchery	Y	522.224.019.006.010.004	785	17060306
TANNEC	Tanner Creek, on Columbia River below Bonneville Dam	N	232	232	17080001
TDA	The Dalles Dam	N	308	308	17070105
TENMIC	Tenmile Creek	N	522.224.120.076	942	17060305
THOMC	Thomas Creek	N	465.145.005	614	17070103
THOP	Thornhollow Acclimation Pond	Y	465.113	578	17070103
TMF	Three Mile Falls Dam (Umatilla River)	N	465.005	0	17070103
TOPPEC	Toppenish Creek	N	539.130	669	17030003
TOUCHR	Touchet River	N	509.035	545	17070102
TROUTC	Trout Creek (trib. to Wind River, Wash.)	N	251.017	268	17070105
TUCH	Tucannon River Hatchery	Y	522.100.058	691	17060107
TUCR	Tucannon River	N	522.100	622	17060107
TURO	Turtle Rock Pond	Y	765	765	17020010
TUTUIC	Tutuilla Creek	N	465.084	548	17070103
TWIS2P	Twisp Acclimation Pond (Methow Salmon Recovery Foundation)	Y	843.066.002	911	17020008
TWISPP	Twisp Acclimation Pond (WDFW)	Y	843.066.008	917	17020008
TWISPR	Twisp River	N	843.066	909	17020008
TWNMIC	Twentymile Creek	N	522.224.120.069	935	17060305
TWNMIT	Twentymile Creek Trap	Y	522.224.120.069.003	938	17060305
UMAH	Umatilla Hatchery	N	*	0	17070101
UMAR	Umatilla River	N	465	465	17070103
UMATNF	North Fork Umatilla River	N	465.145	609	17070103
UMATSF	South Fork Umatilla River	N	465.145	609	17070103
UWH	University of Washington Hatchery	Y	***	0	17110012
VALEYC	Valley Creek	N	522.303.609	1434	17060201
VATC	Vat Creek	N	522.303.633.003	1461	17060201
VGISNB	Van Giessen Bridge	Y	539	539	17030003
WALH	Wallowa Hatchery	Y	522.271.131.063.001	988	17060105
WALLAR	Walla Walla River	N	509	509	17070102

Mark and Recapture Site Codes By Site Code					
Site Code	Location Name	I	River KM	Total RKM	Hydro Unit
WALLNF	North Fork Walla Walla River	N	509.081	590	17070102
WALLOR	Wallowa River	N	522.271.131	924	17060105
WALLSF	South Fork Walla Walla River	N	509.081	590	17070102
WAN	Wannapum Dam	N	669	669	17020010
WAPATC	Wapato Canal	N	539.171	710	17030003
WAPATD	Wapato Dam	Y	539.172	711	17030003
WAPATS	Wapato Screen	Y	539.172.001	712	17030003
WARMSC	Warm Springs Creek	N	522.224.120.037.092	995	17060303
WBIRDC	Whitebird Creek	N	522.303.086	911	17060209
WEL	Wells Dam	N	830	830	17020005
WELH	Wells Hatchery	Y	830	830	17020005
WENATR	Wenatchee River	N	754	754	17020011
WENATT	Wenatchee River Trap at West Monitor Bridge	Y	754.010	764	17020011
WENR	Wenaha River	N	522.271.073	866	17060106
WENRNF	North Fork Wenaha River	N	522.271.073.035	901	17060106
WENRSF	South Fork Wenaha River	N	522.271.073.035	901	17060106
WHITCC	White Cap Creek	N	522.224.120.037.264	1167	17060301
WHITSC	White Sand Creek - Replaced by COLTKC	N	522.224.120.037.113	1016	17060303
WHITSR	White Salmon River	N	271	271	17070105
WILH	Willamette Hatchery (ODFW) at Oakridge	N	*	0	17090001
WILL	Willard National Fish Hatchery	Y	261.009	270	17070105
WILLIC	Williams Creek	N	522.303.622	1447	17060201
WILLR	Willamette River (Archaic - replaced with reach-specific definitions)	N	163	163	170900*
WILLR1	Willamette River - mouth to Willamette Falls (km 0-41)	N	163	163	17090012
WILLR2	Willamette River - Willamette Falls to Santiam River (km 41-175)	N	163	163	17090007
WILLR3	Willamette River - Santiam River to the confluence of the Middle and Coast forks of the Willamette River (km 175-301)	N	163	163	17090003
WILSOC	Wilson Creek, Middle Fork Salmon River	N	522.303.319.037	1181	17060206
WIND2R	Wind River, Washington	N	251	251	17070105
WINDR	Wind River	N	522.303.177	1002	17060207
WINT	Winthrop National Fish Hatchery	Y	843.081	924	17020008
WOPTXD	Wopatox Dam	Y	539.187.028	754	17030002
WPOOSH	Wishpoosh Creek	N	539.299.004	852	17030001
WSPH	Warm Springs National Fish Hatchery	Y	329.135.016	480	17070306
YAKIM1	Yakima River - mouth to Naches River (km 0-187)	N	539	539	17030003
YAKIM2	Yakima River - Naches River to headwaters (km 187-345)	N	539	539	17030001
YAKIMR	Yakima River (Archaic - replaced with reach-specific definitions)	N	539	539	170300*
YANKWF	West Fork Yankee Fork	N	522.303.591.011	1427	17060201

Mark and Recapture Site Codes By Site Code					
Site Code	Location Name	I	River KM	Total RKM	Hydro Unit
YELLJC	Yellowjacket Creek, tributary of Camas Creek, Middle Fork Salmon River	N	522.303.319.057.007	1208	17060206
YELLLC	Yellowbelly Lake Creek	N	522.303.633.001	1459	17060201
		N		0	

2. Mark and Recapture Site Codes By River KM, Site Code

Mark and Recapture Site Codes By River KM, Site Code					
River KM	Location Name	Site Code	I	Total RKM	Hydro Unit
*	Big Beef Creek	BBC	N	0	17110018
*	Bonneville Dam PH1 (Archaic - replaced with generic BON designation)	BO1	N	0	17070105
*	Bonneville Dam PH2 (Archaic - replaced with generic BON designation)	BO2	N	0	17070105
*	Bonneville Dam Complex	BON	N	0	17070105
*	Cassimer Bar Hatchery	CASS	N	0	17020006
*	Chelan PUD Hatchery	CHEL	N	0	17020010
*	Clearwater Hatchery	CLWH	N	0	17060306
*	Eagle Hatchery	EAGL	N	0	17050114
*	East Bank Hatchery	EBNK	N	0	17020010
*	Hagerman NFH	HAGE	N	0	17040212
*	Ice Harbor Dam	IHR	N	0	17060110
*	Irrigon Hatchery	IRRI	N	0	17070101
*	John Day Dam	JDA	N	0	17070105
*	Leaburg Dam	LEA	N	0	17090004
*	Lower Granite Dam	LGR	N	0	17060107
*	Little Goose Dam	LGS	N	0	17060107
*	Lower Monumental Dam	LMN	N	0	17060110
*	Magic Valley Hatchery	MAVA	N	0	17040212
*	McCall Hatchery	MCCA	N	0	17050123
*	McNary Dam	MCN	N	0	17070101
*	Montlake Hatchery	MONT	N	0	17110012
*	Niagara Springs Hatchery	NISP	N	0	17040212
*	Deprecated null value used only to support legacy data.	NONE	N	0	99999999
*	Oxbow Hatchery (IDFG)	OXBO	N	0	17050201
*	Rock Island Dam	RIS	N	0	17020010
*	Rocky Reach Dam	RRE	N	0	17020010
*	Umatilla Hatchery	UMAH	N	0	17070101
*	Willamette Hatchery (ODFW) at Oakridge	WILH	N	0	17090001
***	Lake Washington, Bear Creek Trap	BCTRAP	Y	0	17110012
***	Lake Washington, Cedar River Trap	CRTRAP	Y	0	17110012
***	Lake Washington, Issaquah Creek Trap	ICTRAP	Y	0	17110012
***	Lake Union	LUNION	Y	0	17110012
***	Bear Creek, Lake Washington below Remond Way Bridge	LWBEAR	Y	0	17110012
***	Cedar River, Lake Washington at Logan Street Bridge	LWCEDR	Y	0	17110012
***	Lake Washington, Issaquah Creek at SE 56th Street Bridge	LWISSQ	Y	0	17110012
***	Ballard Locks	LWSCCL	Y	0	17110012
***	Ship Canal, Lake Washington at Fremont Cut/Bridge	LWSCFC	Y	0	17110012
***	Ship Canal, Lake Washington at Montlake Cut/Bridge	LWSCMC	Y	0	17110012
***	Ship Canal, Lake Washington at King	LWSCM	Y	0	17110012

Mark and Recapture Site Codes By River KM, Site Code					
River KM	Location Name	Site Code	I	Total RKM	Hydro Unit
	County/Metro Environmental Lab	L			
***	King County/Metro Environmental Lab	METRO	Y	0	17110012
***	University of Washington Hatchery	UWH	Y	0	17110012
000	Columbia River (Archaic - replaced with reach-specific definitions)	COLR	N	0	170*
000	Columbia River - mouth to Three Tree Point, WA (km 0-49)	COLR1	N	0	17080006
000	Columbia River - Three Tree Point, WA to Lewis River (km 49-140)	COLR2	N	0	17080003
000	Columbia River - Lewis River to Bonneville Dam (km 140-234)	COLR3	N	0	17080001
000	Columbia River - Bonneville Dam to John Day Dam (km 234-347)	COLR4	N	0	17070105
000	Columbia River - John Day Dam to Snake River (km 347-522)	COLR5	N	0	17070101
000	Columbia River - Snake River to Lower Crab Creek (km 522-661)	COLR6	N	0	17020016
000	Columbia River - Lower Crab Creek to Chelan Falls, WA (km 661-809)	COLR7	N	0	17020010
000	Columbia River - Chelan Falls, WA to Grand Coulee Dam (km 809-960)	COLR8	N	0	17020005
006	Chinook River, Washington (Columbia River Estuary)	CHINOR	N	6	17080006
006.006	Sea Resources Hatchery (Chinook River, Washington)	SERH	Y	12	17080006
008	East Sand Island, Columbia River	ESANIS	Y	8	17080006
034	Rice Island	RICEIS	Y	34	17080006
035.002	Deep River Net Pens (Deep River, Washington)	DRNP	Y	37	17080006
043.006	Big Creek Hatchery (ODFW) near Knappa	BIGC	N	49	17080006
047	Blind Slough Net Pens (Oregon side of Columbia River Estuary)	BLNDSL	Y	47	17080006
058.019	Elochoman River Hatchery (Elochoman River, Washington)	ELRH	Y	77	17080003
087	Abernathy Creek, Lower Columbia River, Washington	ABERC	N	87	17080003
087.005	Abernathy SCTC	ABEH	Y	92	17080003
111	Cowlitz River - mouth to Crispus River (km 0-145)	COWLR1	N	111	17080005
111	Cowlitz River - Crispus River to headwaters (km 145-216)	COWLR2	N	111	17080004
111.071	Cowlitz Trout Hatchery	COWT	Y	182	17080005
111.080	Cowlitz Salmon Hatchery	COWS	Y	191	17080005
111.085	Mayfield Dam	MAYD	Y	196	17080005
139	Multnomah Channel, Columbia River	MULTC H	N	139	17090012
139.000	Cunningham Slough	CUNNSL	N	139	17090012
140	Lewis River	LEWISR	N	140	17080002
140.025	Cedar Creek, tributary to Lewis River	CEDARC	N	165	17080002
163	Willamette River (Archaic - replaced	WILLR	N	163	170900*

Mark and Recapture Site Codes By River KM, Site Code					
River KM	Location Name	Site Code	I	Total RKM	Hydro Unit
	with reach-specific definitions)				
163	Willamette River - mouth to Willamette Falls (km 0-41)	WILLR1	N	163	17090012
163	Willamette River - Willamette Falls to Santiam River (km 41-175)	WILLR2	N	163	17090007
163	Willamette River - Santiam River to the confluence of the Middle and Coast forks of the Willamette River (km 175-301)	WILLR3	N	163	17090003
163.040.027.016	Eagle Creek National Fish Hatchery, in Clackamas River Basin	EAGH	Y	246	17090011
163.043	Sullivan Dam	SUL	N	206	17090012
163.174	Santiam River, Oregon	SANTIR	N	337	17090005
163.174.019	North Santiam River, Oregon	NSANTR	N	356	17090005
163.174.019	South Santiam River, Oregon	SSANTR	N	356	17090006
163.174.019.044	Little North Santiam River	LNSANR	N	400	17090005
163.282	McKenzie River	MCKER	N	445	17090004
163.282.053	McKenzie Hatchery	MCKE	Y	498	17090004
163.282.056	Leaburg Hatchery	LEAB	Y	501	17090004
232	Tanner Creek, on Columbia River below Bonneville Dam	TANNEC	N	232	17080001
232.001	Bonneville Hatchery	BONH	Y	233	17080001
251	Wind River, Washington	WIND2R	N	251	17070105
251.007	Panther Creek (trib. to Wind River, Wash.)	PANT2C	N	258	17070105
251.017	Trout Creek (trib. to Wind River, Wash.)	TROUTC	N	268	17070105
251.028	Carson National Fish Hatchery	CARS	Y	279	17070105
261.002	Little White Salmon National Fish Hatchery	LWSH	Y	263	17070105
261.009	Willard National Fish Hatchery	WILL	Y	270	17070105
269	Spring Creek National Fish Hatchery	SPRC	Y	269	17070105
271	White Salmon River	WHITSR	N	271	17070105
271.002	Big White Salmon Ponds	BIGWSP	Y	273	17070105
271.012	Rattlesnake Creek	RATTLC	N	283	17070105
308	The Dalles Dam	TDA	N	308	17070105
314	Little Memaloose Island, Columbia River	LMEMIS	Y	314	17070105
328	Deschutes River - mouth to Round Butte Dam (0-178 km)	DESCH1	N	328	17070306
328.161	Pelton Ladder	PELTON	Y	489	17070306
329.135.016	Warm Springs National Fish Hatchery	WSPH	Y	480	17070306
331	Little Miller Island, Columbia River	LMILIS	Y	331	17070105
351	John Day River (Archaic - replaced with reach-specific definitions)	JDAR	N	351	170702*
351	John Day River - mouth to North Fork John Day River (km 0-298)	JDAR1	N	351	17070204
351	John Day River - North Fork John Day River to headwaters (km 298-454)	JDAR2	N	351	17070201
351.298	North Fork John Day River	JDARNF	N	649	17070202
351.298.052	Middle Fork John Day River	JDARMF	N	701	17070203
351.341	South Fork John Day River	JDARSF	N	692	17070201

Mark and Recapture Site Codes By River KM, Site Code					
River KM	Location Name	Site Code	I	Total RKM	Hydro Unit
351.341.023	Black Canyon Creek, South Fork John Day River	JSFBC	N	715	17070201
351.341.027	Murderers Creek, South Fork John Day River	JSFMC	N	719	17070201
351.341.028	Deer Creek, South Fork John Day River	JSFDC	N	720	17070201
351.341.033	Wind Creek, South Fork John Day River	JSFWC	N	725	17070201
412	Three Mile Canyon Island (Col. R. below Blalock Island)	3MLIS	Y	412	17070101
465	Umatilla River	UMAR	N	465	17070103
465.005	Three Mile Falls Dam (Umatilla River)	TMF	N	0	17070103
465.077	Birch Creek	BIRCHC	N	541	17070103
465.077.026	East Fork Birch Creek	BIRCHE	N	567	17070103
465.077.026	West Fork Birch Creek	BIRCHW	N	567	17070103
465.077.026.018	Pearson Creek	PEARSC	N	585	17070103
465.082	McKay Creek	MCKAY C	N	546	17070103
465.084	Tutuilla Creek	TUTUIC	N	548	17070103
465.090	Pendleton Acclimation Pond	PENP	Y	555	17070103
465.098	Mission Creek (Umatilla River)	MISSNC	N	562	17070103
465.105	Cottonwood Creek (Umatilla River)	COTTW C	N	569	17070103
465.108	Moonshine Creek	MOONS C	N	572	17070103
465.109	Coonskin Creek	COONSC	N	573	17070103
465.109	Minthorn Acclimation Pond	MINP	Y	574	17070103
465.113	Thornhollow Acclimation Pond	THOP	Y	578	17070103
465.117	Buckaroo Creek	BCKROC	N	581	17070103
465.123	Imeqes Acclimation Pond	IMQP	Y	588	17070103
465.124	Squaw Creek (Umatilla River)	SQAWC	N	588	17070103
465.127	Meacham Creek	MEACH C	N	591	17070103
465.127.003	Bonifer Springs Acclimation Pond	BONP	Y	595	17070103
465.127.003	Boston Canyon Creek	BOSTCC	N	594	17070103
465.127.008	Line Creek	LINEC	N	599	17070103
465.127.018	Camp Creek	CAMPC	N	609	17070103
465.127.024	North Fork Meacham Creek	MEACH N	N	615	17070103
465.127.031	East Fork Meacham Creek	MEACH E	N	622	17070103
465.127.034	Butcher Creek	BUTCHC	N	625	17070103
465.132	Ryan Creek	RYANC	N	596	17070103
465.145	North Fork Umatilla River	UMATN F	N	609	17070103
465.145	South Fork Umatilla River	UMATSF	N	609	17070103
465.145.002	Buck Creek	BUCKC	N	611	17070103
465.145.005	Coyote Creek	COYOTC	N	614	17070103
465.145.005	Thomas Creek	THOMC	N	614	17070103
465.145.008	Shimmihorn Creek	SHIMC	N	617	17070103
509	Walla Walla River	WALLA R	N	509	17070102

Mark and Recapture Site Codes By River KM, Site Code					
River KM	Location Name	Site Code	I	Total RKM	Hydro Unit
509.035	Touchet River	TOUCHR	N	545	17070102
509.035.087	Dayton Acclimation Pond	DAYP	Y	631	17070102
509.054	Mill Creek, Walla Walla River	MILLC	N	563	17070102
509.081	North Fork Walla Walla River	WALLNF	N	590	17070102
509.081	South Fork Walla Walla River	WALLSF	N	590	17070102
510	Crescent Island, Columbia River	CRISIS	Y	510	17070101
512	Badger Island, Columbia River	BADGEI	Y	512	17070101
518	Foundation Island, Columbia River	FOUNDI	Y	518	17070101
522	Snake River - mouth to Palouse River (km 0-96)	SNAKE1	N	522	17060110
522	Snake River - Palouse River to Clearwater River (km 96-224)	SNAKE2	N	522	17060107
522	Snake River - Clearwater River to Salmon River (km 224-303)	SNAKE3	N	522	17060103
522	Snake River - Salmon River to Hells Canyon Dam (km 303-397)	SNAKE4	N	522	17060101
522	Snake River (Archaic - replaced with reach-specific definitions)	SNAKER	N	522	170601*
522.095	Lyons Ferry Hatchery	LYFE	Y	617	17060107
522.100	Tucannon River	TUCR	N	622	17060107
522.100.058	Tucannon River Hatchery	TUCH	Y	691	17060107
522.100.066	Curl Lake Rearing Pond	CURP	Y	701	17060107
522.224	Clearwater River	CLWR	N	746	17060306
522.224.010	Clearwater Trap	CLWTRP	Y	756	17060306
522.224.019	Lapwai Creek	LAPC	N	765	17060306
522.224.019.001	North Lapwai Valley Acclimation Pond	NLVP	Y	766	17060306
522.224.019.006.010.004	Sweetwater Springs Hatchery	SWSP	Y	785	17060306
522.224.019.016	Mission Creek	MISSC	N	781	17060306
522.224.024	Potlatch River	POTR	N	770	17060306
522.224.031	Cottonwood Creek	COTNW C	N	777	17060306
522.224.038	Nez Perce Tribal Hatchery	NPTH	Y	784	17060306
522.224.042	Bedrock Creek	BEDRKC	N	788	17060306
522.224.047	Jacks Creek	JACKSC	N	793	17060306
522.224.057	Big Canyon Creek Acclimation Facility (Clearwater River)	BCCAP	Y	803	17060306
522.224.057	Big Canyon Creek	BIGCAC	N	803	17060306
522.224.057.005	Little Canyon Creek	LITCAC	N	808	17060306
522.224.065	North Fork Clearwater River	CLWRNF	N	811	17060308
522.224.065	Dworshak National Fish Hatchery	DWOR	Y	811	17060306
522.224.065	Dworshak NFH, release into mainstem Clearwater River	DWORM S	Y	811	17060306
522.224.065.000	Dworshak NFH, release into North Fork Clearwater River	DWORN F	Y	811	17060308
522.224.072	Orofino Creek	OROFC	N	818	17060306
522.224.087	Lolo Creek	LOLOC	N	833	17060306
522.224.087.041	Eldorado Creek	ELDORC	N	874	17060306
522.224.120	Middle Fork Clearwater River	CLWRM F	N	866	17060304
522.224.120	South Fork Clearwater River	CLWRSF	N	866	17060305

Mark and Recapture Site Codes By River KM, Site Code					
River KM	Location Name	Site Code	I	Total RKM	Hydro Unit
522.224.120.004	Clear Creek	CLEARC	N	870	17060304
522.224.120.004.001	Kooskia National Fish Hatchery	KOOS	Y	871	17060304
522.224.120.037	Lochsa River	LOCHSA	N	903	17060303
522.224.120.037	Selway River - mouth to Moose Creek (km 0-65)	SELWY1	N	903	17060302
522.224.120.037	Selway River - Moose Creek to headwaters (km 65-147)	SELWY2	N	903	17060301
522.224.120.037	Selway River	SELWYR	N	903	17060302
522.224.120.037.003	Pete King Creek	PETEKC	N	906	17060303
522.224.120.037.012	Canyon Creek	CANYO C	N	915	17060303
522.224.120.037.012	O'Hara Creek	OHARA C	N	915	17060302
522.224.120.037.016	Deadman Creek	DEADM C	N	919	17060303
522.224.120.037.028	Old Man Creek	OLDMA C	N	931	17060303
522.224.120.037.029	Gedney Creek	GEDNEC	N	932	17060302
522.224.120.037.029.005	West Fork Gedney Creek	GEDCW F	N	937	17060302
522.224.120.037.031	Meadow Creek, Selway River	MEADO C	N	934	17060302
522.224.120.037.039	Fish Creek	FISHC	N	942	17060303
522.224.120.037.039.002	Fish Creek Trap	FISTRP	Y	944	17060303
522.224.120.037.039.007	Hungry Creek (Lochsa River Basin)	HUNGC	N	949	17060303
522.224.120.037.042	Boulder Creek	BOULDC	N	945	17060303
522.224.120.037.042.001	Boulder Creek Trap	BOUTRP	Y	946	17060303
522.224.120.037.051	Three Links Creek	3LINKC	N	954	17060302
522.224.120.037.051	Mink Creek	MINKC	N	954	17060302
522.224.120.037.065	Moose Creek (Selway River)	MOOS2C	N	968	17060302
522.224.120.037.065.006	North Fork Moose Creek, Selway River	MOOS2N	N	974	17060302
522.224.120.037.081	Bear Creek	BEARC	N	984	17060301
522.224.120.037.082	Post Office Creek	POSTOC	N	985	17060303
522.224.120.037.092	Warm Springs Creek	WARMS C	N	995	17060303
522.224.120.037.096	Squaw Creek	SQUAW C	N	999	17060303
522.224.120.037.105	Papoose Creek	PAPOOC	N	1008	17060303
522.224.120.037.113	Colt Kill Creek - Replaces WHITSC	COLTKC	N	1016	17060303
522.224.120.037.113	Crooked Fork Creek	CROOKC	N	1016	17060303
522.224.120.037.113	Powell Rearing Pond	POWP	Y	1016	17060303
522.224.120.037.113	White Sand Creek - Replaced by COLTKC	WHITSC	N	1016	17060303
522.224.120.037.113.003	Crooked Fork Creek Trap	CFCTRP	Y	1019	17060303
522.224.120.037.113.011	Brushy Fork Creek	BRUSHC	N	1027	17060303
522.224.120.037.113.016	Storm Creek	STORMC	N	1032	17060303
522.224.120.037.113.020	Colt Creek	COLTC	N	1036	17060303
522.224.120.037.113.026	Big Flat Creek	BIGFLC	N	1042	17060303
522.224.120.037.253	Running Creek	RUNNIC	N	1156	17060301
522.224.120.037.253.003	Eagle Creek	EAGLEC	N	1159	17060301

Mark and Recapture Site Codes By River KM, Site Code					
River KM	Location Name	Site Code	I	Total RKM	Hydro Unit
522.224.120.037.264	White Cap Creek	WHITCC	N	1167	17060301
522.224.120.053	Meadow Creek, South Fork Clearwater	MEAD2C	N	919	17060305
522.224.120.056	Johns Creek	JOHNC	N	922	17060305
522.224.120.069	Twentymile Creek	TWNMIC	N	935	17060305
522.224.120.069.003	Twentymile Creek Trap	TWNMIT	Y	938	17060305
522.224.120.076	Tenmile Creek	TENMIC	N	942	17060305
522.224.120.084	Newsome Creek	NEWSO C	N	950	17060305
522.224.120.094	Crooked River	CROOKR	N	960	17060305
522.224.120.094.001	Crooked River Trap	CROTRP	Y	961	17060305
522.224.120.094.013	Relief Creek	RELIEC	N	973	17060305
522.224.120.094.015	Crooked River Pond	CROOKP	Y	975	17060305
522.224.120.094.018	Five Mile Creek	FIVEMC	N	978	17060305
522.224.120.101	American River	AMERR	N	967	17060305
522.224.120.101	Red River	REDR	N	967	17060305
522.224.120.101.006	Red River Trap	REDTRP	Y	973	17060305
522.224.120.101.027	Red River Rearing Pond	REDP	N	994	17060305
522.224.120.101.028	South Fork Red River	REDRSF	N	995	17060305
522.225	Snake Trap	SNKTRP	Y	747	17060103
522.263	Captain John Rapids Acclimation Pond	CJRAP	Y	785	17060103
522.271	Grande Ronde River - mouth to Wallowa River (km 0-131)	GRAND1	N	793	17060106
522.271	Grande Ronde River - Wallowa River to headwaters (km 131-325)	GRAND2	N	793	17060104
522.271	Grande Ronde River (Archaic - replaced with reach-specific definitions)	GRAND R	N	793	170601*
522.271.002	Grande Ronde River Trap	GRNTRP	Y	795	17060106
522.271.046	Cottonwood Acclimation Pond	COTP	Y	839	17060106
522.271.073	Wenaha River	WENR	N	866	17060106
522.271.073.035	North Fork Wenaha River	WENRN F	N	901	17060106
522.271.073.035	South Fork Wenaha River	WENRSF	N	901	17060106
522.271.131	Wallowa River	WALLO R	N	924	17060105
522.271.131.016	Minam River	MINAM R	N	940	17060105
522.271.131.018.001	Big Canyon Facility	BCANF	Y	943	17060105
522.271.131.042	Lostine River	LOSTIR	N	966	17060105
522.271.131.042.001	Lostine River Weir	LOSTIW	Y	967	17060105
522.271.131.042.021	Lostine River Pond	LOSTIP	Y	987	17060105
522.271.131.063.001	Wallowa Hatchery	WALH	Y	988	17060105
522.271.137	Lookingglass Creek	LOOKGC	N	930	17060104
522.271.137.003	Lookingglass Hatchery	LOOH	Y	933	17060104
522.271.232	Catherine Creek	CATHEC	N	1025	17060104
522.271.232.032	Catherine Creek Weir	CATHE W	Y	1057	17060104
522.271.232.044	Little Catherine Creek	LCATHC	N	1069	17060104
522.271.232.048	Catherine Creek Pond	CATHEP	Y	1073	17060104
522.271.232.052	North Fork Catherine Creek	CATCNF	N	1077	17060104
522.271.232.052	South Fork Catherine Creek	CATCSF	N	1077	17060104

Mark and Recapture Site Codes By River KM, Site Code					
River KM	Location Name	Site Code	I	Total RKM	Hydro Unit
522.271.232.052.005	Middle Fork Catherine Creek	CATCMF	N	1082	17060104
522.271.307	Grande Ronde River Weir	GRAND W	Y	1100	17060104
522.271.320	Grande Ronde River Pond	GRANDP	Y	1113	17060104
522.303	Salmon River (Archaic - replaced with reach-specific definitions)	SALR	N	825	170602*
522.303	Salmon River - mouth to above French Creek (km 0-171)	SALR1	N	825	17060209
522.303	Salmon River - above French Creek to Middle Fork Salmon River (km 171-319)	SALR2	N	825	17060207
522.303	Salmon River - Middle Fork Salmon River to Pahsimeroi River (km 319-489)	SALR3	N	825	17060203
522.303	Salmon River - Pahsimeroi River to headwaters (km 489-650)	SALR4	N	825	17060201
522.303.086	Whitebird Creek	WBIRDC	N	911	17060209
522.303.103	Salmon Trap	SALTRP	Y	910	17060209
522.303.106	Slate Creek	SLATEC	N	931	17060209
522.303.140	Little Salmon River	LSALR	N	965	17060210
522.303.140.007	Rapid River, Little Salmon River	RAPIDR	N	972	17060210
522.303.140.007.006	Rapid River Hatchery	RAPH	Y	978	17060210
522.303.140.007.007	Rapid River Trap	RPDTRP	Y	979	17060210
522.303.140.007.012	West Fork Rapid River	RAPIWF	N	984	17060210
522.303.140.031	Hazard Creek	HAZARC	N	996	17060210
522.303.140.031.002	Hard Creek	HARDC	N	698	17060210
522.303.160	Partridge Creek	PARTRC	N	985	17060209
522.303.169	French Creek	FRENCH	N	994	17060209
522.303.177	Wind River	WINDR	N	1002	17060207
522.303.188	Sheep Creek	SHEEPC	N	1013	17060207
522.303.200	Crooked Creek	CROOC	N	1025	17060207
522.303.215	Lower South Fork Salmon River Trap	LSFTRP	N	1040	17060208
522.303.215	South Fork Salmon River	SALRSF	N	1040	17060208
522.303.215.059	Secesh River	SECESR	N	1099	17060208
522.303.215.059.008	Lick Creek	LICKC	N	1107	17060208
522.303.215.059.045	Lake Creek	LAKEC	N	1144	17060208
522.303.215.060	East Fork South Fork Salmon River	SAEFSF	N	1100	17060208
522.303.215.060.024	Johnson Creek	JOHNSC	N	1124	17060208
522.303.215.060.024.007	Johnson Creek Trap	JOHTRP	Y	1131	17060208
522.303.215.060.024.024	Burnt Log Creek	BURNLC	N	1148	17060208
522.303.215.111	South Fork Salmon River Weir	SALSFW	Y	1151	17060208
522.303.215.112	Knox Bridge	KNOXB	Y	1152	17060208
522.303.215.115	South Fork Salmon River Trap	SFSTRP	Y	1155	17060208
522.303.215.125	Stolle Pond	STOLP	Y	1165	17060208
522.303.223	Jersey Creek	JERSEC	N	1048	17060207
522.303.247	Big Mallard Creek	BIGMAC	N	1072	17060207
522.303.255	Bargamin Creek	BARGAC	N	1080	17060207
522.303.272	Sabe Creek	SABEC	N	1097	17060207
522.303.282	Chamberlain Creek	CHAMB C	N	1107	17060207
522.303.282.024	West Fork Chamberlain Creek	CHAMW F	N	1131	17060207

Mark and Recapture Site Codes By River KM, Site Code					
River KM	Location Name	Site Code	I	Total RKM	Hydro Unit
522.303.282.027	Flossie Creek	FLOSSC	N	1134	17060207
522.303.282.031	Moose Creek	MOOSEC	N	1138	17060207
522.303.301	Horse Creek	HORSEC	N	1126	17060207
522.303.319	Middle Fork Salmon River - mouth to Loon Creek (km 0-73)	SALMF1	N	1144	17060206
522.303.319	Middle Fork Salmon River - Loon Creek to headwaters (km 73-170)	SALMF2	N	1144	17060205
522.303.319	Middle Fork Salmon River	SALRMF	N	1144	17060206
522.303.319.029	Big Creek, Middle Fork Salmon River	BIG2C	N	1173	17060206
522.303.319.029.011	Rush Creek, tributary of Big Creek, Middle Fork Salmon River	RUSHC	N	1184	17060206
522.303.319.037	Wilson Creek, Middle Fork Salmon River	WILSOC	N	1181	17060206
522.303.319.049	Sheep Creek, Middle Fork Salmon River	SHEPC	N	1193	17060206
522.303.319.057	Camas Creek, Middle Fork Salmon River	CAMASC	N	1201	17060206
522.303.319.057.007	Yellowjacket Creek, tributary of Camas Creek, Middle Fork Salmon River	YELLJC	N	1208	17060206
522.303.319.073	Loon Creek	LOONC	N	1217	17060205
522.303.319.110	Indian Creek, Middle Fork Salmon River	INDIAC	N	1254	17060205
522.303.319.118	Pistol Creek, Middle Fork Salmon River	PISTOC	N	1262	17060205
522.303.319.124	Rapid River, Middle Fork Salmon River	RAPR	N	1268	17060205
522.303.319.150	Sulphur Creek, Middle Fork Salmon River	SULFUC	N	1294	17060205
522.303.319.154	Boundary Creek	BOUND C	N	1298	17060205
522.303.319.155	Dagger Creek	DAGGEC	N	1299	17060205
522.303.319.163	Fall Creek	FALLC	N	1307	17060205
522.303.319.170	Bear Valley Creek	BEARVC	N	1314	17060205
522.303.319.170	Marsh Creek	MARSH C	N	1314	17060205
522.303.319.170.010	Capehorn Creek	CAPEHC	N	1324	17060205
522.303.319.170.011	Marsh Creek Trap	MARTRP	Y	1325	17060205
522.303.319.170.014	Elk Creek	ELKC	N	1328	17060205
522.303.319.170.015	Knapp Creek	KNAPPC	N	1329	17060205
522.303.338	Panther Creek (Salmon River)	PANTHC	N	1163	17060203
522.303.381	North Fork Salmon River	SALRNF	N	1206	17060203
522.303.416	Lemhi River	LEMHIR	N	1241	17060204
522.303.416.049	Lemhi River Weir	LEMHIW	Y	1290	17060204
522.303.489	Pahsimeroi River	PAHSIR	N	1314	17060202
522.303.489.002	Pahsimeroi Weir	PAHSIW	Y	1316	17060202
522.303.489.002	Pahsimeroi River Trap	PAHTRP	Y	1316	17060202
522.303.489.011	Pahsimeroi Pond	PAHP	N	1325	17060202
522.303.552	East Fork Salmon River	SALREF	N	1377	17060201
522.303.552.014	Herd Creek	HERDC	N	1391	17060201
522.303.552.029	East Fork Salmon River Trap	SALEFT	Y	1406	17060201
522.303.552.030	East Fork Salmon River Weir	SALEFW	Y	1407	17060201
522.303.564.001	Squaw Creek Acclimation Pond	SQUAW P	Y	1390	17060201
522.303.591.011	West Fork Yankee Fork	YANKW	N	1427	17060201

Mark and Recapture Site Codes By River KM, Site Code					
River KM	Location Name	Site Code	I	Total RKM	Hydro Unit
		F			
522.303.609	Stanley (Gage 2945)	STANLE	Y	1434	17060201
522.303.609	Valley Creek	VALEYC	N	1434	17060201
522.303.609.009	Stanley Lake Creek	STANLC	N	1443	17060201
522.303.615	Redfish Lake Creek	REDFLC	N	1440	17060201
522.303.615.003	Redfish Lake Creek Trap	RLCTR	Y	1443	17060201
522.303.615.005	Redfish Lake	REDFL	Y	1445	17060201
522.303.617	Sawtooth Hatchery	SAWT	Y	1442	17060201
522.303.617	Sawtooth Trap	SAWTRP	Y	1442	17060201
522.303.621	Gold Creek	GOLDC	N	1446	17060201
522.303.622	Williams Creek	WILLIC	N	1447	17060201
522.303.624	Huckleberry Creek	HUCKLC	N	1449	17060201
522.303.624.001	Decker Creek	DECKEC	N	1450	17060201
522.303.628	Fisher Creek	FISHEC	N	1453	17060201
522.303.630	Fourth of July Creek	4JULYC	N	1455	17060201
522.303.631	Champion Creek	CHAMP C	N	1456	17060201
522.303.631	Hell Roaring Creek	HELLRC	N	1456	17060201
522.303.631	Mays Creek	MAYSC	N	1456	17060201
522.303.633	Alturas Lake Creek	ALTULC	N	1458	17060201
522.303.633.001	Yellowbelly Lake Creek	YELLLC	N	1459	17060201
522.303.633.002	Pettit Lake Creek	PETTLC	N	1460	17060201
522.303.633.002.002	Pettit Lake	PETTL	Y	1462	17060201
522.303.633.003	Vat Creek	VATC	N	1461	17060201
522.303.633.011	Alturas Lake	ALTURL	Y	1469	17060201
522.303.642	Beaver Creek	BEAVEC	N	1467	17060201
522.303.642	Pole Creek	POLEC	N	1467	17060201
522.303.644	Smiley Creek	SMILEC	N	1469	17060201
522.303.647	Frenchman Creek	FRENCC	N	1472	17060201
522.308	Imnaha River	IMNAHR	N	830	17060102
522.308.007	Imnaha Trap	IMNTRP	Y	837	17060102
522.308.008	Lightning Creek - Imnaha River	LITNGC	N	838	17060102
522.308.032	Big Sheep Creek	BSHEEC	N	862	17060102
522.308.032.005.008	Little Sheep Facility	LSHEEF	Y	875	17060102
522.308.074	Imnaha River Weir	IMNAH W	Y	904	17060102
522.346	Pittsburg Landing Acclimation Facility	PLAP	Y	868	17060101
522.397	Hells Canyon Dam	HCD	N	919	17060101
539	Van Giessen Bridge	VGISNB	Y	539	17030003
539	Yakima River - mouth to Naches River (km 0-187)	YAKIMI	N	539	17030003
539	Yakima River - Naches River to headwaters (km 187-345)	YAKIM2	N	539	17030001
539	Yakima River (Archaic - replaced with reach-specific definitions)	YAKIMR	N	539	170300*
539.076	Chandler Canal	CHANDL	N	615	17030003
539.076	Prosser Dam	PROSRD	Y	615	17030003
539.076	Prosser Trap	PROTRP	Y	617	17030003
539.112	Satus Creek, Yakima River	SATUSC	N	651	17030003
539.130	Toppenish Creek	TOPPEC	N	669	17030003

Mark and Recapture Site Codes By River KM, Site Code					
River KM	Location Name	Site Code	I	Total RKM	Hydro Unit
539.167	Sunnyside Dam	SSD	N	706	17030003
539.167	Sunnyside Canal	SSIDEC	N	706	17030003
539.167.001	Sunnyside Screen	SSIDES	Y	707	17030003
539.171	Wapato Canal	WAPAT C	N	710	17030003
539.172	Ahtanum Creek, Yakima River	AHTANC	N	711	17030003
539.172	Wapato Dam	WAPAT D	Y	711	17030003
539.172.001	Wapato Screen	WAPATS	Y	712	17030003
539.187	Natches River	NATCHR	N	726	17030002
539.187.028	Wopatox Dam	WOPTX D	Y	754	17030002
539.206	Rosa Dam	ROSAD	Y	745	17030001
539.270	Clark Flat Acclimation Pond	CLARFP	Y	809	17030001
539.284.017.009	Jack Creek Acclimation Pond	JACKCP	Y	849	17030001
539.293	Cle Elum Hatchery	CLEE	Y	832	17030001
539.299	Cle Elum River	CLELMR	N	838	17030001
539.299.004	Wishpoosh Creek	WPOOS H	N	852	17030001
539.299.013	Cle Elum Dam	CLELMD	Y	851	17030001
539.325	Easton Acclimation Pond	EASTOP	Y	864	17030001
545	Richland Island, Columbia River	RICHIS	Y	545	17020016
549	Island 18, Columbia River	IS18	Y	549	17020016
567	Ringold Hatchery	RINH	Y	567	17020016
639	Priest Rapids Dam	PRD	N	639	17020016
639	Priest Rapids Hatchery	PRDH	Y	639	17020016
669	Wannapum Dam	WAN	N	669	17020010
677	I-90 bridge over Columbia River upstream of Wannapum Dam	I-90B	Y	677	17020010
754	Wenatchee River	WENAT R	N	754	17020011
754.010	Wenatchee River Trap at West Monitor Bridge	WENAT T	Y	764	17020011
754.026	Dryden Acclimation Pond	DRYP	Y	780	17020011
754.029	Peshastin River	PESHAR	N	783	17020011
754.041	Icicle Creek	ICICLC	N	795	17020011
754.041.005	Leavenworth National Fish Hatchery	LEAV	Y	800	17020011
754.077	Chiwawa River	CHIWAR	N	831	17020011
754.077.002	Chiwawa Rearing Pond	CHIP	Y	833	17020011
754.077.002	Chiwawa River Trap, 0.5 km below CHIP acclimation pond	CHIWAT	Y	833	17020011
754.089	Nason Creek (tributary to Wenatchee River)	NASONC	N	843	17020011
765	Turtle Rock Pond	TURO	Y	765	17020010
778	Entiat River	ENTIAR	N	778	17020010
778.017	Entiat NFH	ENTH	Y	795	17020010
830	Wells Dam	WEL	N	830	17020005
830	Wells Hatchery	WELH	Y	830	17020005
843	Methow River	METHR	N	843	17020008
843.058	Carlton Acclimation Pond	CARP	Y	902	17020008

Mark and Recapture Site Codes By River KM, Site Code					
River KM	Location Name	Site Code	I	Total RKM	Hydro Unit
843.066	Twisp River	TWISPR	N	909	17020008
843.066.002	Twisp Acclimation Pond (Methow Salmon Recovery Foundation)	TWIS2P	Y	911	17020008
843.066.008	Twisp Acclimation Pond (WDFW)	TWISPP	Y	917	17020008
843.080	Chewuch River	CHEWU R	N	923	17020008
843.080.010	Chewuch Acclimation Pond (WDFW)	CHEWU P	Y	933	17020008
843.081	Winthrop National Fish Hatchery	WINT	Y	924	17020008
843.085	Methow Hatchery	METH	Y	928	17020008
858	Okanogan River	OKANR	N	858	17020006
858.055	Salmon Creek (tributary to Okanogan River)	SALMOC	N	913	17020006
858.064	Omak Creek (tributary to Okanogan River)	OMAKC	N	922	17020006
858.119	Similkameen River	SIMILR	N	977	17020007
858.119.008	Similkameen Acclimation Pond (replaces archaic SIMP)	SIMILP	Y	985	17020007
858.130	Osoyoos Lake	OSOL	Y	988	17020006
941.121.008	Similkameen Pond (Archaic - Replaced by SIMILP)	SIMP	N	1070	17020007
---	Potholes Reservoir, Grant County, Washington	POTHOL	Y	0	17020015
~	Ocean Recovery	OCEAN	Y	0	N/A
			N	0	

3. Intra-Dam Release Site Codes

These codes are appended as a suffix to the three-character dam site code and provide a specific location for release at, above, or below hydroelectric facilities. For example, a release into the gate-wells at Lower Granite Dam would be coded as LGRGWL. The use of Intra-Dam Release Site Codes has been required since 12/31/99.

site	location name
BPS	Release into the PIT-Tag Diversion System between the Diversion Gate and the furthest downstream PIT-Tag Detector
BYP	Release into the Facility Bypass Flume/Pipe
COL	Release into the Collection Channel upstream of the Dewatering Facility
DTG	Release into the Collection Flume/Pipe between the Dewatering Facility and the Collection/Bypass Gate
DWT	Release into the Dewatering Facility
FBY	Release into the Forebay within 0.5 km upstream of Dam
GAT	Release into Flume between Separator Exit and the Primary PIT-Tag Diversion Gate
GWL	Release into Gatewell(s)
ICE	Release into the Ice/Trash Sluiceway
MRT	Mortality Recovery
OFL	Release into the PIT-Tag Diversion System downstream of the Last PIT-Tag Detector
ORI	Release into Orifice(s)
RBR	Release below the PIT-Tag Diversion System Gate with subsequent Barge Transportation from the Facility
RRR	Release below the PIT-Tag Diversion System Gate with subsequent Return to the River at the Facility
RTR	Release below the PIT-Tag Diversion System Gate with subsequent Truck Transportation from the Facility
RXR	Release below the PIT-Tag Diversion System Gate with subsequent Transportation from the Facility
SEP	Release into the Flume downstream of the Collection/Bypass Gate or into the Separator
SPF	Release into the Forebay within 0.5 km upstream of Spillway
SPL	Release directly into Spill Bay(s)
SPT	Release into the Tailrace within 0.5 km downstream of Spillway
SRR	Release into the Separator Return Flume/Pipe with Direct Return to the River
STS	Release onto the Submerged Traveling Screen
TAL	Release into the Tailrace within 0.5 km downstream of Dam
TRB	Release into Turbine(s)

K. PIT Tag Steering Committee Members, 2003

Ed Buettner

Idaho Department of Fish & Game
1540 Warner Ave.
Lewiston, ID 83501
ebuettner@idfg.state.id.us
Ph: (208) 799-3475
Fax: (208) 799-5012

Doug Marsh

National Marine Fisheries Service
2725 Montlake Blvd.
Seattle, WA 98112
doug.marsh@noaa.gov
Ph: (206) 860-3235
Fax: (206) 860-3267

Charles Morrill

Washington Department of Fish & Wildlife
600 N. Capitol Way
Olympia, WA 98504
cfwdfw@aol.com
Ph: (360) 902-2747
Fax: (360) 902-2183

Ann Setter

Oregon Department of Fish & Wildlife
65495 Alder Slope Rd.
Enterprise, OR 97828
asetter@oregonVOS.net
Ph: (541) 426-9052
Fax: (541) 426-3055

Carter Stein

Pacific States Marine Fisheries Commission
45 SE 82nd Drive, Suite 100
Gladstone, OR 97027
carters@psmfc.org
Ph: (503) 650-5400
Fax: (503) 650-5426

Joe Zydlewski

U.S. Fish and Wildlife Service
9317 N.E. Highway 99, Ste. 1
Vancouver, WA 98665
joe_zydlewski@fws.gov
Ph: (360) 696-7605
Fax: (360) 696-7968

V. Glossary of Terms

ASSOCIATED MARKS

A field in the (archaic) Release Information File used to record identifying marks, other than PIT tags, associated with a group of fish being released, (*e.g.*, freeze brands, fin clips, coded wire tags, or VI tags).

BROOD YEAR

A field in a Tagging File used, as needed, to record the last two digits of the year a hatchery stock was spawned.

CAPTURE METHOD

A field in a Tagging File used to record the method used to collect fish.

CHECKSUM

An (archaic) field in a Tagging File detail record used to record a two-character hexadecimal value that confirms the validity of a 400 kHz PIT tag.

COLLECTION SITE

A field in the (archaic) Mortality File used to record the six-character code of the denoting the point of collection. Obsolete.

Comment: We need to indicate where this is in the current Tag File; unfortunately, we currently use the Tag Site field, but we SHOULD use the Release Site (and associated River KM) fields. Once we do this, it needs to be documented here.

COIL

A loop antenna, made from a coil of wire, which transmits a signal that excites a PIT tag, and then receives a return signal from the PIT tag. Coils or loops are found in all interrogation equipment, from tabletop detectors to automatic interrogation systems.

COIL ID

The unique identifier associated with each coil of automatic interrogation systems.

CONDITIONAL COMMENT

A field in a Tagging File detail record used to record coded references to fish condition, and other key criteria. The PTAGIS Data System will not accept data files containing unrecognized Conditional Comments.

COORDINATOR ID

A field in Tagging Files used to record the (generally) three-character initials of the Coordinator. The Coordinator is responsible for the marking or recovery operation utilizing the PIT tags, and for responding to queries from other entities regarding those operations. Coordinators are **not** necessarily directly involved in data collection.

CREATION DATE

A field in the (archaic) Mortality File used to record the date the file was created, and used as the default date of observed mortality. Obsolete. The **TAG DATE** field in the general-purpose TAGGING FILE serves the same purpose when referencing detail records denoting mortality events.

DETECTOR

A colloquial term used to describe one or more coil assemblies used to interrogate PIT-tagged fish.

DIVERSION GATE

A mechanical gate (such as a rotating- or slide-gate) used to selectively route or segregate fish.

EPA-REACH

See USGS HYDROLOGIC UNIT.

FILE TITLE

The file ID or name given to a PIT tag data file. Each File Title must be unique from all others in the Columbia River Basin and therefore it is very important to follow the formats described in the PIT tag Specification Document for each individual file type. Files containing computer-generated File Title declarations cannot be renamed without also editing the declaration within the file.

FILE TYPE RECORD

This record is present in Tagging and Interrogation files. It designates the format, content, and function of PIT tag data files.

FIXED REFERENCE TAG

A tag having a unique code and an internal clock that is permanently connected inside of a PIT tag monitor; used to test the performance of individual coils. It receives power from the excitation coil and automatically transmits its code at a regular interval. Also known as a "Timer Tag."

FLAG CODE

See Conditional Comment.

FORK LENGTH

A field in a Tagging File detail record used to record the length of a fish from the tip of the snout to the fork of the tail, recorded in millimeters.

GIS HYDRO UNIT

See USGS HYDROLOGIC UNIT.

HATCHERY SITE

A field in a Tagging File used, as needed, to record a four-character abbreviation of the hatchery at which the fish were reared.

HEADER RECORD

A record found at the beginning of a Tagging File describing parameters global to the detail records in the file.

INTERROGATION FILE

A data file of passive PIT tag detections, created with the MiniMon.exe or MultiMon.exe software programs, and containing (at a minimum) the PIT tag codes, dates and times of interrogation, and the coil IDs on which the tags were interrogated.

ISO

International Standards Organization.

ISO 11784 / 11785

These are the international standards related to the Radio Frequency ID technology used in PIT tags. 11784 defines the 128 bits of the tag telegram message, also referred to as the datagram. 11785 defines the technical parameters of the tag. For example, the ISO tag activation frequency is 134.2 kHz.

MAIN SITE

For the purpose of PTAGIS database reports, specific interrogation sites are classified as a "Main" site. Special database processing occurs for sites that are classified as "Main" sites. Specifically, the first interrogation of a PIT tag at a "Main" site will create an "obs_main" record in the database. Subsequent interrogations of this PIT tag record at other "Main" sites will not generate further obs_main records.

MIGRATION YEAR

A field in a Tagging File used to record the last two digits of the earliest calendar year when fish are expected to smolt and out-migrate to the ocean. In the case of adults and/or recaptured fish, this value will generally reference the current year.

MINIMON.EXE

A software program that provides automated data entry of PIT tag passive interrogation data.

MONITOR

A group of detectors around the same pipe or flume within the same or adjoining shielding boxes, with no gates between them; a set of PIT tag detectors within one shielded unit.

MORTALITY

A PIT tag that is recovered with or without the host animal, subsequent to the tagged release of the animal. See "Mortality Events" in Section III.2: Conditional Comments.

MORTALITY FILE

An obsolete data file input format originally used to report PIT tag mortality events. These events are now recorded and reported to PTAGIS using the standard Tagging File format.

MULTIMON.EXE

A software program that provides automated data entry of PIT tag passive interrogation data. In addition, the MULTIMON.EXE program provides logical control for the operation of fish diversion gates, and includes a "Separation by Code" (SbyC) capability that permits the identification and segregation of individual PIT-tagged fish based on each tag's unique hexadecimal code.

NOTE RECORD

A comment section in a Tagging File. Depending on the context in which they are recorded and used, note records can pertain to a group of fish or to an individual fish. Note records are not processed by, or incorporated into the PTAGIS database.

OBSERVATION

A colloquial name for an interrogation event recorded in an Interrogation File.

ORGANIZATION

A field in Tagging Files used to record the code for the entity responsible for data collection.

P3.EXE

A 32-bit Windows™ data entry software program used to record tagging, recapture, and mortality events. PITTAG2.EXE also integrates real-time, context-sensitive, data validation, and complete support for ISO-compatible 134.2 kHz PIT tag codes. Replaces the PITTAG2.EXE program. PASS-THROUGH REFERENCE TAG

A PIT tag embedded in a wooden block and passed through an interrogation system to determine coil, interrogation unit, and system reading efficiencies. Also called STICK TAGS.

PIT (Passive Integrated Transponder) TAG

A computer chip attached to a wire antenna and encapsulated in a biologically inert glass capsule. The tag is excited when it is passed through the electromagnetic field of a detector and the Tag ID encoded on the computer chip is transmitted to the detector.

PITTAG2.EXE

A 32-bit Windows™ data entry software program used to record tagging, recapture, and mortality events. PITTAG2.EXE also integrates real-time, context-sensitive, data validation, and complete support for ISO-compatible 134.2 kHz PIT tag codes. Replaced by the **P3.EXE** program.

PIT TAG DIVERSION GATE

Any mechanical device used to route or divert PIT-tagged fish. The gate is activated by a Programmable Logic Controller (PLC) attached to a PIT tag detector.

PIT TAG INTERROGATION SYSTEM

All of the equipment related to exciting, detecting, and on-site recording of PIT tags.

PIT TAG STEERING COMMITTEE (PTSC)

A subcommittee of the Fish Passage Advisory Committee of the Columbia Basin Fish and Wildlife Authority. The Committee is made up of technical representatives of the Basin's fisheries agencies and tribes. The Committee's function is to provide guidance in the development of tagging methodologies and data standards and to serve as a technical forum for the operation of PTAGIS and the PIT tag data collection and data distribution system.

PIT CODE

A unique 10- or 14-character hexadecimal code recorded on the computer chip in the PIT tag. PTAGIS applications refer to this value as the Tag ID.

POSITIONAL COMMENT

A field in a Tagging File detail record used to record specific, pre-formatted codes pertaining to an individual fish. Currently there are predefined values and formats for Species, Run, Rearing Type, and Release Time Variable codes. Individual researchers can designate their own additional positional comments for their own use, but they will not be stored in the PTAGIS data system.

POST TAGGING TEMP

A field in a Tagging File used to record the water temperature (C°) in a pond or raceway when fish are held for an extended period of time prior to release. This variable should be left blank if the fish are released immediately.

PTAGIS

The PIT Tag Information System. This is the central repository of all the information generated by the PIT tag System of the Columbia River Basin. PTAGIS is managed by the Pacific States Marine Fisheries Commission and funded by the Bonneville Power Administration.

PTOC

The PIT tag Operations Center. This term is redundant with PTAGIS. It refers to the operational aspects of the Columbia Basin PIT Tag Information System (PTAGIS) project. This acronym is from the Charter agreement for the PIT Tag Steering Committee between the Columbia Basin Fish and Wildlife Authority and the Pacific States Marine Fisheries Commission. According to the Charter, PTOC administers the PTAGIS database, operates and maintains all detection equipment at the main-stem Columbia and Snake river dams, and creates and updates data collection software for the Columbia River Basin PIT tag System – this is by definition the PTAGIS project.

RACEWAY/TRANSECT

This refers to a field in a Tagging File used, as needed, to record the raceway or transect number or designation used to identify the group of PIT-tagged fish.

REARING TYPE

A one-character code within the Positional Comments section of a Tagging File detail record used to indicate the rearing status (hatchery, wild, or unknown) of a fish.

RECAPTURE

A PIT-tagged fish that is handled subsequent to the release event. A recaptured fish must be designated with the "RE" flag code.

RECOVERY ORGANIZATION

A field in the (archaic) Mortality File used to record the code of the agency or organization responsible for the collection and reporting of mortality data. Obsolete. The **ORGANIZATION** field in the general-purpose TAGGING FILE serves the same purpose when referencing detail records denoting mortality events.

RELEASE DATE

A field in a Tagging File used to record the date that fish are released to a river or stream, after being PIT-tagged, to rear or out-migrate naturally.

RELEASE RIVER KM

A field in a Tagging File used to record the location of release, in river kilometers. This is a hierarchical coding scheme from the mouth of the Columbia River to the release site (up to 7th order streams for point release sites) with each tributary delimited with a period. For example, the Release River KM for Lower Granite Dam of 522.173

reflects a distance of 522 km from the mouth of the Columbia River to the mouth of the Snake River, and 173 km from the mouth of the Snake River to Lower Granite Dam.

RELEASE INFORMATION FILE

The (archaic) Release Information File consisted of information about a Tagging File or files that was not available at the time of tagging. Obsolete. Release information is now incorporated directly into the TAGGING FILE

RELEASE SITE

A field in a Tagging File containing the site or body of water that PIT-tagged fish are released into.

RELEASE WATER TEMP

A field in a Tagging File containing the temperature (C°) of the body of water that PIT-tagged fish are released into to rear naturally or migrate downstream.

RIVER REACH

See USGS HYDROLOGIC UNIT.

RUN

A one-digit code within the Positional Comments section of a Tagging File detail record used to indicate the season the adult fish return from saltwater (*e.g.*, spring chinook, summer steelhead, etc.).

SEQUENCE NUMBER

A field in a Tagging File detail record containing a sequential number, from 1 to 9999, that individually identifies each Tag Detail record within a Tagging File.

SESSION MESSAGE

A field in a Tagging File used to summarize the purpose and function of the data set.

SPECIES

A one-digit code within the Positional Comments section of a Tagging File detail record used to indicate the species of the fish being tagged.

STICK TAG

See PASS-THROUGH REFERENCE TAG.

STOCK

A field in a Tagging File used, as needed, to record a brief descriptor of the brood stock, such as "Rapid River" or "Wells".

SWING GATE

A gate positioned in a flume where that flume splits into two. The gate selects one of the two by blocking the other and changes by swinging across the original flume.

TAG DATE

A field in a Tagging File used to record the date the fish were tagged or recovered. The PITTAG2.EXE and P3.EXE software programs default to the current date and time.

TAG DETAIL RECORD

That portion of a Tagging File containing the PIT code, length, weight, species, race, rearing type, and any comments associated with each individual tagged fish.

TAG SITE

A field in a Tagging File used to record the code (four to six characters) representing the geographic location of the tagging or recovery operation.

TAGGER

This field in a Tagging File can be used to record the last name and initial of the first name of the primary person doing the tag injection for that specific file. It is also conventionally used to record the name of the project supervisor.

TAGGING FILE

A data file containing information pertaining to the original marking and release, recapture, or mortality of PIT-tagged fish.

TAGGING METHOD

A field in a Tagging File used to record the method of injecting tags into fish. If the data file contains only recapture or mortality information, the Tagging Method is denoted as "NONE."

TAGGING TEMP

The temperature (C°) of the tagging bath during the marking operation.

TEST TAG

A special tag (*e.g.*, "Stick Tag" or "Fixed Reference Tag") registered by PTOC and used to test interrogation efficiency.

TEXTUAL COMMENT

A field in a Tagging File detail record containing an *ad hoc* text descriptor pertaining to an individual fish.

TIMER TAG

See FIXED REFERENCE TAG.

TRANSPORTATION DURATION

A field in the (archaic) Release Information file used to report the duration of time from loading of fish onto the transport vehicle until they are released into the stream. Obsolete.

TRANSPORTATION TYPE

A field in the (archaic) Release Information file used to report the method of transport to the release site. Obsolete.

USGS HYDROLOGIC UNIT

An eight-digit code representing the primary through quaternary classifications of geographic mapping in the United States.

VARIABLE RELEASE TIME

A method of assigning multiple Release Dates (and times) to groups of fish within a Tagging File. If groups of fish within a Tagging File are being tagged and released to a stream independently of other groups within the same Tagging File then release date and times must be recorded for each group of fish. This is done with the Release Time Variable, which is a Positional Comment value ranging from 00 to 99. There must be a corresponding Variable Release Time declaration in the Tagging File to define each unique Release Time Variable referenced in the Tag Detail section.

WEIGHT

A field in a Tagging File used to report the weight of the fish, recorded in tenths of grams.

Appendix A. Hydrologic Unit Codes

Adapted from Seaber, P.R., Kapinos, F.P., and Knapp, G.L., 1987, Hydrologic Unit Maps: U.S. Geological Survey Water-Supply Paper 2294, 63 p.

A1. Classification System

The United States was divided and sub-divided into successively smaller hydrologic units which were classified into four levels: regions, sub-regions, accounting units, and cataloging units. The hydrologic units are arranged within each other, from the smallest (cataloging units) to the largest (regions). Each hydrologic unit is identified by a unique hydrologic unit code (HUC) consisting of two to eight digits based on the four levels of classification in the hydrologic unit system.

The first level of classification divides the Nation into 21 major geographic area, or regions. These geographic areas (hydrologic areas based on surface topography) contain either the drainage area of a major river, such as the Missouri region, or the combined drainage areas of a series of rivers, such as the Texas-Gulf region, which includes a number of rivers draining into the Gulf of Mexico.

The second level of classification divides the 21 regions into 222 sub-regions. A sub-region includes the area drained by a river system, a reach of a river and its tributaries in that reach, a closed basin(s), or a group of streams forming a coastal drainage area.

The third level of classification subdivides many of the sub- regions into accounting units.

The fourth level of classification is the cataloging unit, the smallest element in the hierarchy of hydrologic units. A cataloging unit is a geographic area representing part or all of a surface drainage basin, a combination of basins, or a distinct hydrologic feature.

A2. Explanation of Hydrologic Unit Codes

An eight-digit code uniquely identifies each of the four levels of classification within four two-digit fields. The first two digits identify the water-resources region; the first four digits identify the sub-region; the first six digits identify the accounting unit, and the addition of two more digits for the cataloging unit completes the eight-digit code. An example is given here using hydrologic unit code (HUC) 01080204:

01 - the region

0108 - the sub-region

010802 - the accounting unit

01080204 - the cataloging unit

An 00 in the two-digit accounting unit field indicates that the accounting unit and the sub-region are the same. Likewise, if the cataloging unit field is 00, it is the same as the accounting unit.

A3. Hydrologic Unit Names

In addition to hydrologic unit codes, each hydrologic unit has been assigned a name corresponding to the principal hydrologic feature(s) within the unit. In the absence of such features, the assigned name may reflect a cultural or political feature within the unit. All regions and sub-regions are uniquely named; however, the accounting units are uniquely named only within each region, and the cataloging units are uniquely named only within each accounting unit. Duplication of some names at the cataloging unit level is unavoidable because a large number of streams found throughout the Nation share the same names.

A4. List of Hydrologic Unit Codes

These codes cover anadromous salmonid habitat above Bonneville Dam.

Sub-region	Accounting Unit	Cataloging Unit	Name	Area (sq. mi.)
1702	Upper Columbia: The Columbia River Basin within the United States above the confluence with the Snake River Basin, excluding the Yakima River Basin. Washington.			22600
	170200		Upper Columbia. Washington	22600
		17020001	Franklin D. Roosevelt Lake. Washington	2170
		17020002	Kettle. Washington	966
		17020003	Colville. Washington	1030
		17020004	Sanpoil. Washington	1080
		17020005	Chief Joseph. Washington	1390
		17020006	Okanogan. Washington	1640
		17020007	Similkameen. Washington	671
		17020008	Methow. Washington	1820
		17020009	Lake Chelan. Washington	955
		17020010	Upper Columbia-Entiat. Washington	1520
		17020011	Wenatchee. Washington	1350
		17020012	Moses Coulee. Washington	926
		17020013	Upper Crab. Washington	1860
		17020014	Banks Lake. Washington	609
		17020015	Lower Crab. Washington	2510
		17020016	Upper Columbia-Priest Rapids. Washington	2070
1703	Yakima. The Yakima River Basin. Washington.			6210
	170300		Yakima. Washington	6210
		17030001	Upper Yakima. Washington	2130
		17030002	Naches. Washington	1130
		17030003	Lower Yakima, Washington	2950
1706	Lower Snake: The Snake River Basin below Hells Canyon Dam to its			35200

Sub-region	Accounting Unit	Cataloging Unit	Name	Area (sq. mi.)
	confluence with the Columbia River. Idaho, Oregon, Washington			
170601			Lower Snake: The Snake River Basin below Hells Canyon Dam to its confluence with the Columbia River, excluding the Salmon and Clearwater River Basins. Idaho, Oregon, Washington.	11800
	17060101		Hells Canyon. Idaho, Oregon	545
	17060102		Imnaha. Oregon	855
	17060103		Lower Snake-Asotin. Idaho, Oregon, Washington	711
	17060104		Upper Grande Ronde. Oregon	1650
	17060105		Wallowa. Oregon	950
	17060106		Lower Grande Ronde. Oregon, Washington	1530
	17060107		Lower Snake-Tucannon. Washington	1480
	17060108		Palouse. Idaho, Washington	2360
	17060109		Rock. Idaho, Washington.	962
	17060110		Lower Snake. Washington	731
170602			Salmon: The Salmon River Basin. Idaho.	14000
	17060201		Upper Salmon. Idaho	2410
	17060202		Pahsimeroi. Idaho	825
	17060203		Middle Salmon-Panther. Idaho	1810
	17060204		Lemhi. Idaho	1270
	17060205		Upper Middle Fork Salmon. Idaho	1490
	17060206		Lower Middle Fork Salmon. Idaho	1370
	17060207		Middle Salmon-Chamberlain. Idaho	1700
	17060208		South Fork Salmon. Idaho	1310
	17060209		Lower Salmon. Idaho	1240
	17060210		Little Salmon. Idaho	582
170603			Clearwater: The Clearwater River Basin. Idaho, Washington	9420
	17060301		Upper Selway. Idaho	997
	17060302		Lower Selway. Idaho	1030
	17060303		Lochsa. Idaho	1180
	17060304		Middle Fork Clearwater. Idaho	213
	17060305		South Fork Clearwater. Idaho	1170
	17060306		Clearwater. Idaho, Washington	2340
	17060307		Upper North Fork Clearwater. Idaho	1320
	17060308		Lower North Fork Clearwater. Idaho	1170
1707	Middle Columbia: The Columbia River Basin below the confluence with the Snake River Basin to Bonneville Dam. Oregon, Washington.			29800
170701			Middle Columbia: The Columbia River Basin below the	11200

Sub-region	Accounting Unit	Cataloging Unit	Name	Area (sq. mi.)
			confluence with the Snake River Basin to Bonneville Dam, excluding the Deschutes and John Day River Basins. Oregon, Washington.	
		17070101	Middle Columbia-Lake Wallula. Oregon, Washington	2550
		17070102	Walla Walla. Oregon, Washington	1750
		17070103	Umatilla. Oregon	2540
		17070104	Willow. Oregon	881
		17070105	Middle Columbia-Hood. Oregon, Washington	2170
		17070106	Klickitat. Washington	1330
170702			John Day: The John Day River Basin. Oregon	7910
		17070201	Upper John Day. Oregon	2130
		17070202	North Fork John Day. Oregon	1830
		17070203	Middle Fork John Day. Oregon	785
		17070204	Lower John Day. Oregon	3160
170703			Deschutes: The Deschutes River Basin. Oregon	10700
		17070301	Upper Deschutes. Oregon	2140
		17070302	Little Deschutes. Oregon	1020
		17070303	Beaver-South Fork. Oregon	1530
		17070304	Upper Crooked. Oregon.	1150
		17070305	Lower Crooked. Oregon	1840
		17070306	Lower Deschutes. Oregon	2300
		17070307	Trout. Oregon	695

Appendix B. Monitor Naming Standards

B1. Naming Standard for PIT Tag Monitors at Juvenile Fish Facilities

Begin at the first monitor(s) the fish encounter upon entering the facility (generally, this will be at the debris and size separator). To name each monitor, take the first of the following that applies to the monitor's location within the plumbing.

1. If the monitor comes directly from the separator, such that all fish leaving the separator through that flume pass through that monitor (with no intervening gates or splits), name it "SEPARATOR".
2. If the monitor is not in the PIT Tag diversion system, but leads to any one of the following (trace the pipes and flumes downstream of the monitor), name the monitor after what it goes to:

RACEWAY	Raceway(s): If a particular set, append that set's name.
RIVER	Back to the river
TRUCK	Truck loading
BARGE	Barge loading
TRANSPORT	Either truck or barge loading
EXIT	Back to the river, or truck or barge loading

If one term completely describes the monitor's location, use it. Otherwise, use all necessary terms to describe the monitor (*e.g.*, RACEWAY/EXIT).

3. If the monitor is located between the Corps sample gate and the sample holding tank (the monitor may be before or after the sample head box), name it "SUBSAMPLE".
4. If the monitor is between the Corps sample holding tank and the lab, name it "SAMPLE ROOM".
5. If the monitor is the first monitor encountered after a PIT Tag diversion gate, name it "DIVERSION".
6. If the monitor is in the PIT Tag diversion system, but is not the first monitor encountered, call it "DIVERSION" plus the applicable term(s) from item 2 above (*e.g.*, "DIVERSION EXIT").

Some of these naming conventions will be modified based on certain design features if the facility:

1. If there are two parallel paths through part or all of the facility, beginning with the separator, add the prefix "A" or "B" to each monitor in the parallel portion; "A" will be the first encountered by the flow through the separator; and "B" the second (such as "A SEPARATOR", "B TRANSPORT"). If there are more than two parallel paths, continue with "C" and "D", etc. as prefixes. Only use these prefixes for as long as the paths are parallel from the separator.
2. If there are two parallel paths through part of the facility, but they diverge from a point other than the separator, include the suffix "1" or "2" to each monitor in the parallel portion; "1" will be the first encountered by the flow into the parallel sections, "2" the

second (e.g., "DIVERSION 1", "DIVERSION 2"). If there are more than two parallel paths, continue with "3", "4", etc. Only use these suffixes for as long as the paths are parallel.

3. If the monitor controls a diversion gate, suffix "GATE" to the monitor. NOTE: If there are several coils in line, some controlling a diversion gate and others not, those that control the gate should be designated as a separate monitor from the others.
4. Abbreviations may be used to shorten the name of a monitor, providing the abbreviations are commonly known (e.g., "E" for "EAST") and do not create a situation where two monitors have the same name.

B2. Naming Standard Example

At Little Goose, there are 10 monitors. The first four coming from the separator are two 2-coil units that control the diversion gates and an additional 2-coil unit in line with each of the first. These are parallel; two are gate controllers. They are called "A SEPARATOR", "A SEPARATOR GATE", "B SEPARATOR", and "B SEPARATOR GATE".

Continuing down the undiverted path, each side has a monitor just after the Corps sample gates. The flow from these monitors can be sent to the raceways, truck loading, barge loading, or to the river. Since they are still parallel; these monitors are called "A RACEWAY/EXIT" and "B RACEWAY/EXIT".

Going down the diversion system, the flumes which carry the fish from the diversion gates lead to separate head boxes, then down separate pipes with monitors to holding tanks. Since these are also parallel, they are called "A DIVERSION" and "B DIVERSION".

There is one more monitor in the diversion system; this one leads to truck loading, barge loading, or to the river. The two sides come together before this monitor; therefore it is called "DIVERSION/EXIT".

The last monitor is in the Corps Sample; it leads into the lab, after the holding tank. It is called "SAMPLE ROOM".

Appendix C. Interrogation Site Configurations

This appendix contains diagrams of Interrogation Sites currently maintained by the PIT Tag Operations Center (PTOC), and the complete configuration history for all Interrogation Site data defined in the PIT Tag Information System (PTAGIS). If you need additional information about any Interrogation Site, please contact PTOC.

C1. Bonneville Adult Lab (B2A)

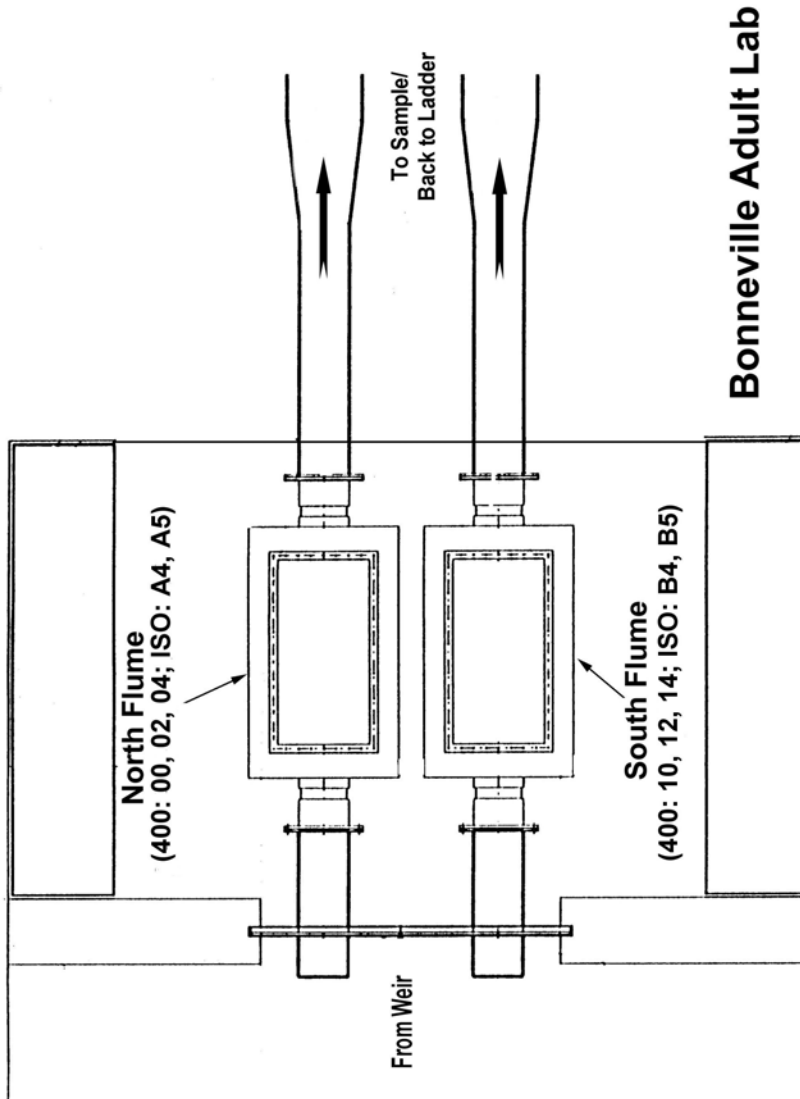

C2. Bonneville Dam PH2 (B2J)

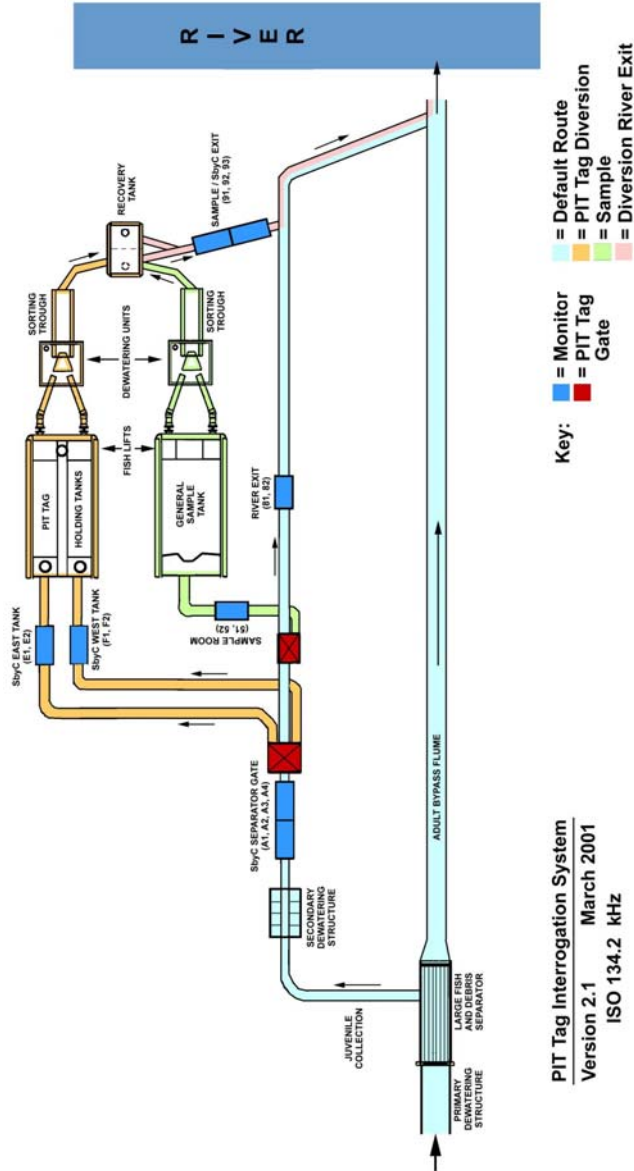

C3. Bonneville Dam PH1 (BVX)

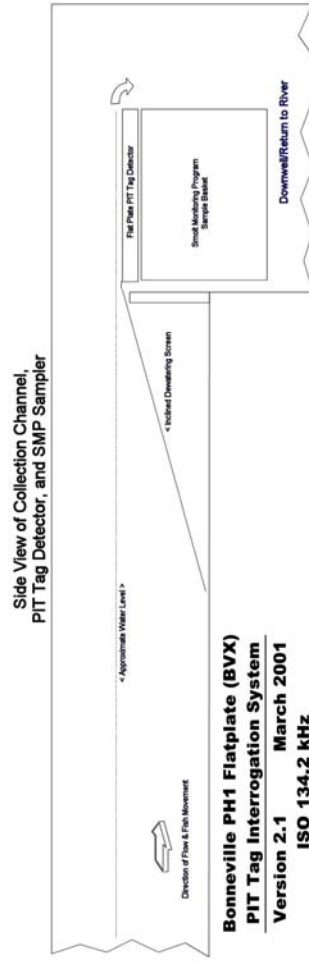

C4. Clark Flat Facility (CFJ)

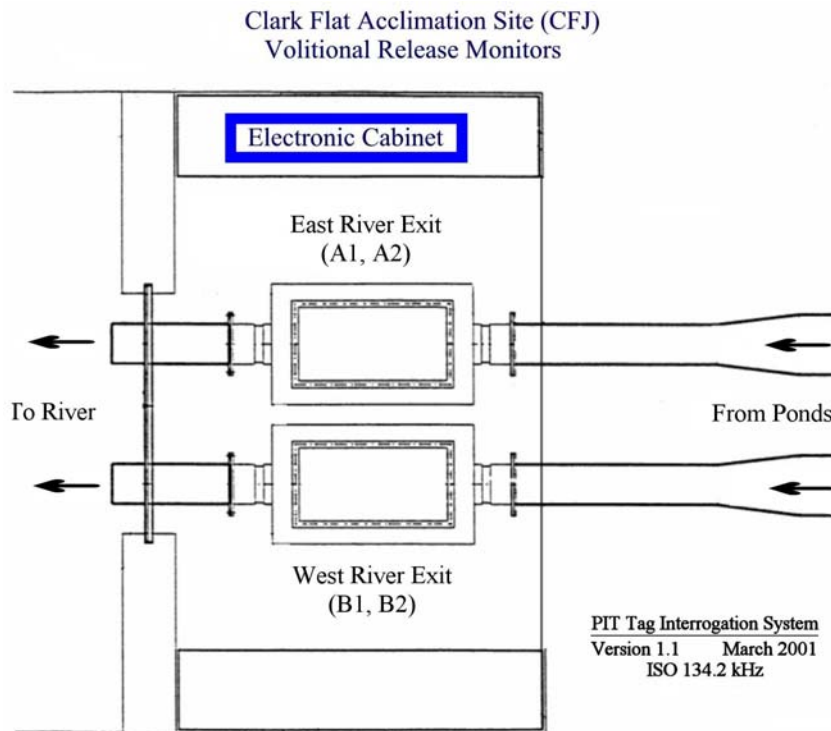

C5. Easton Facility (ESJ)

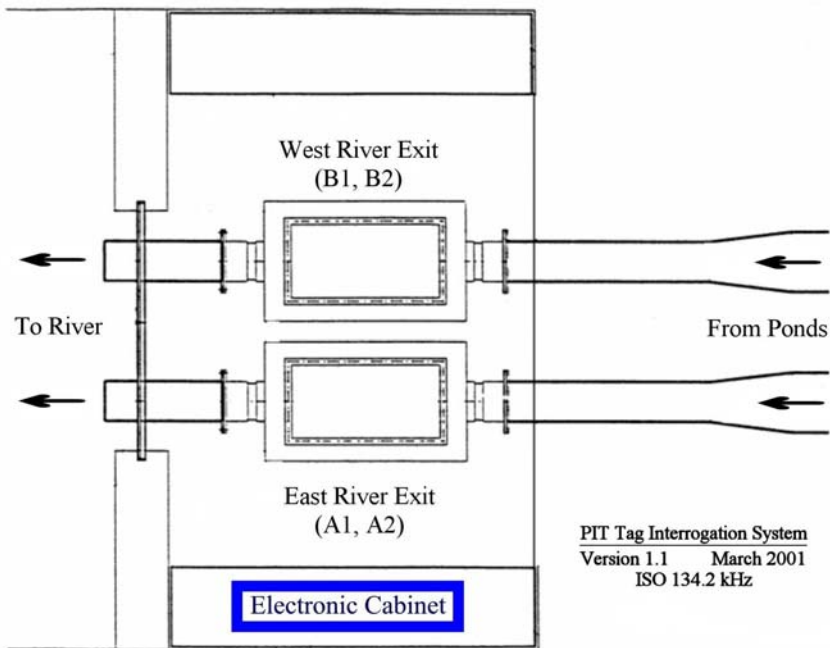

C6. Little Goose Dam (GOJ)

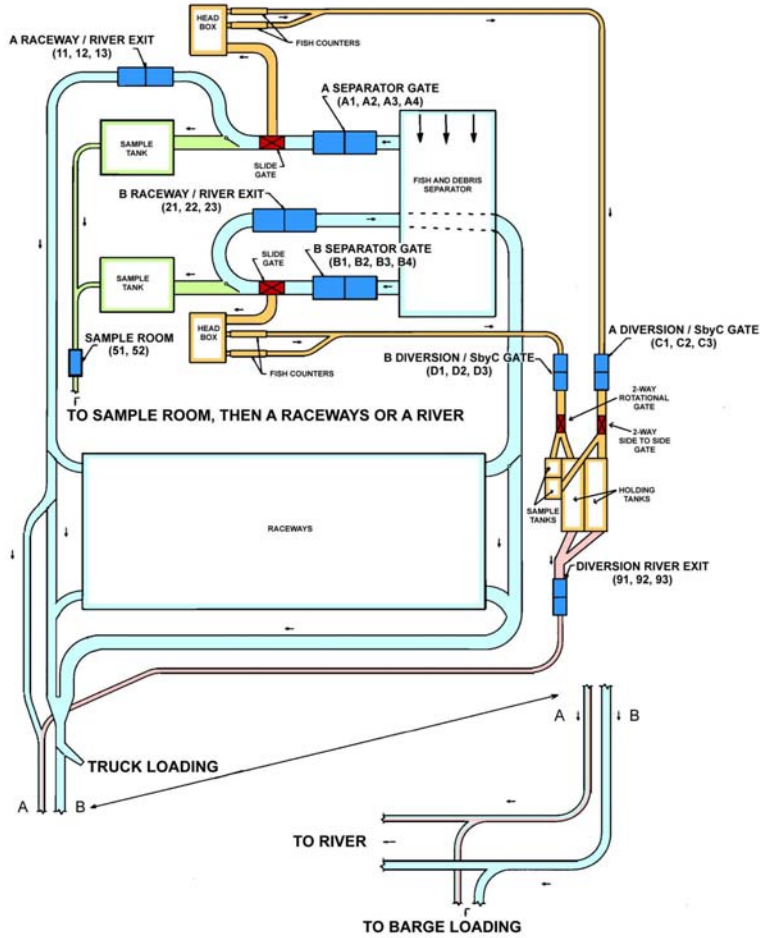

PIT Tag Interrogation System
 Version 2 March 2000
 ISO 134.2 kHz

Key: ■ = Monitor ■ = Default Route
■ = PIT Tag Gate ■ = PIT Tag Diversion
■ = Sample ■ = Diversion River Exit

C7. Lower Granite Adult Trap (GRA)

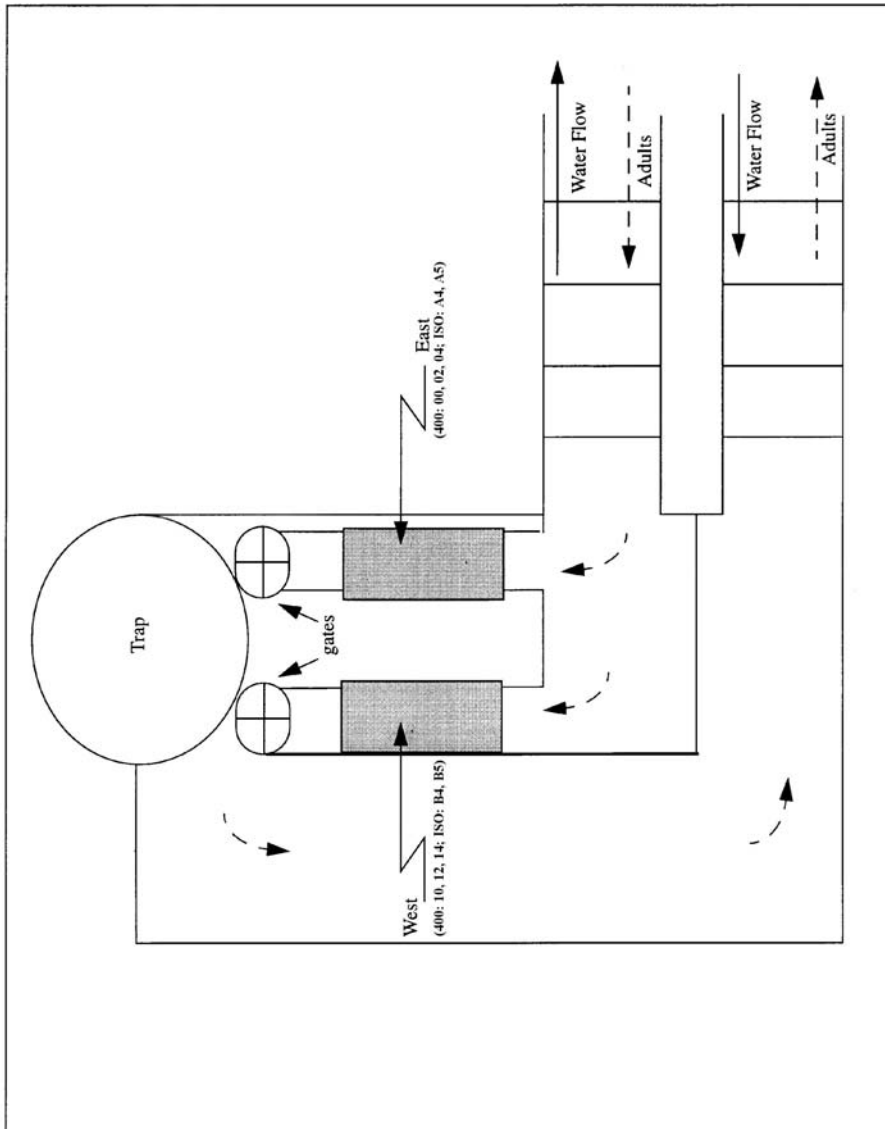

C8. Lower Granite Dam (GRJ)

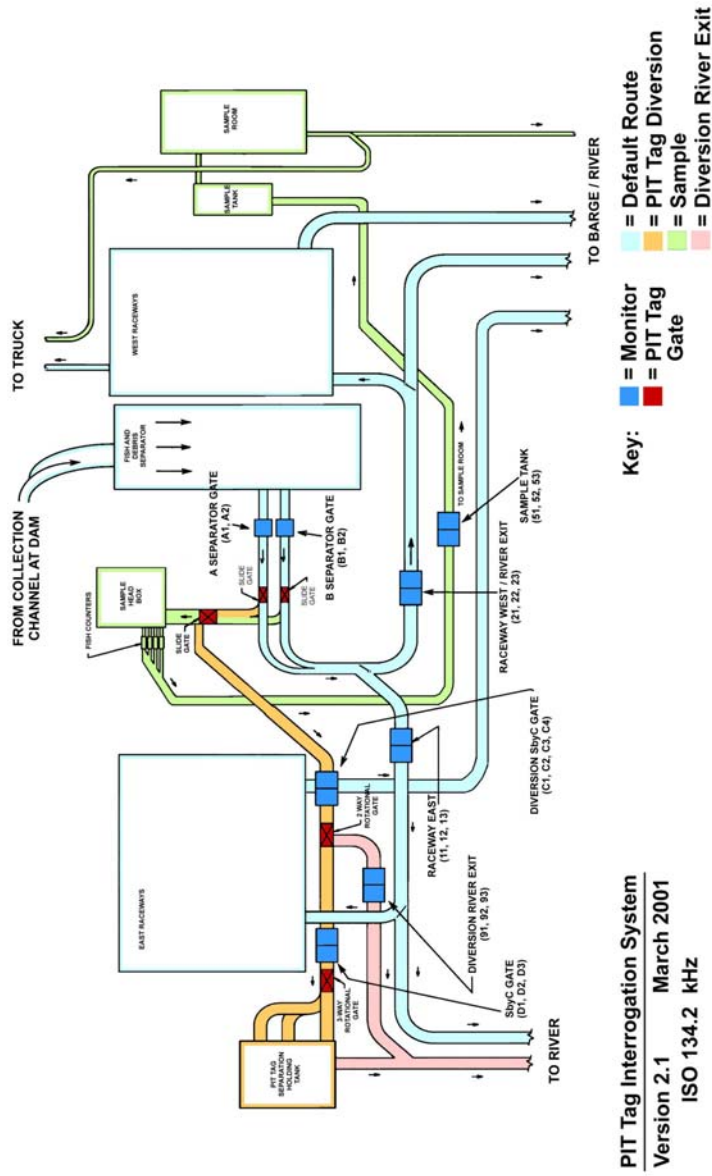

C9. Jack Creek Facility (JCJ)

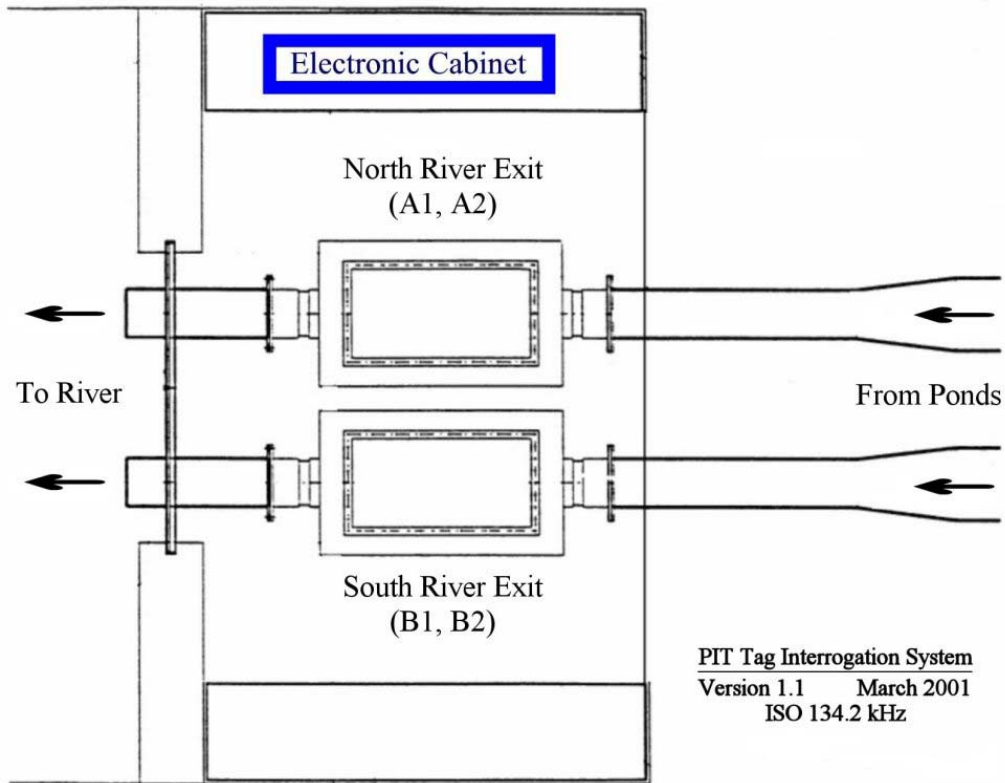

C10. John Day Dam (JDJ)

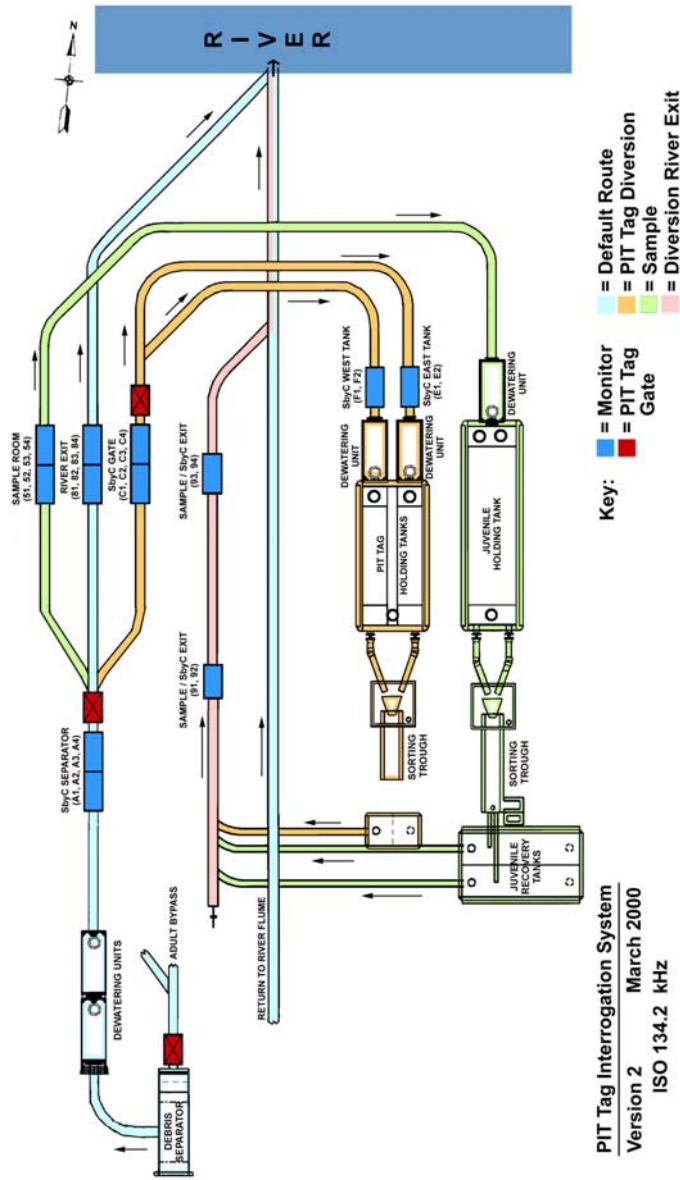

C12. McNary Dam (MCJ)

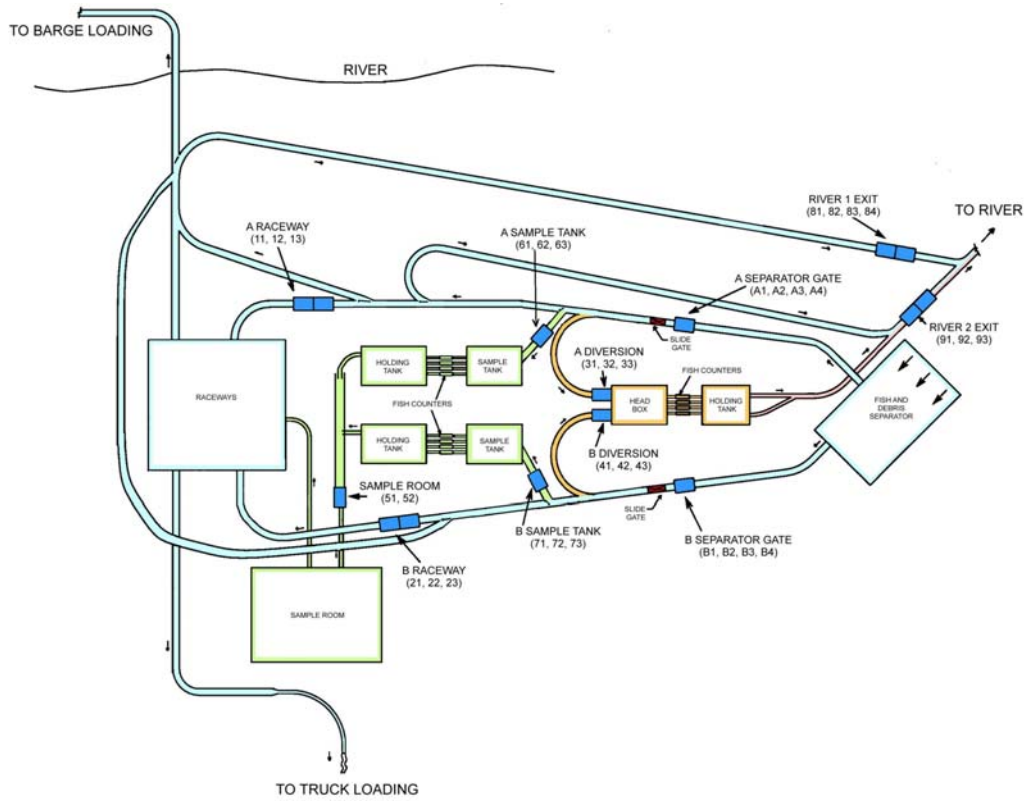

PIT Tag Interrogation System
 Version 2 March 2000
 ISO 134.2 kHz

Key:

■ = Monitor	■ = Default Route
■ = PIT Tag Gate	■ = PIT Tag Diversion
	■ = Sample
	■ = Diversion River Exit

C13. Prosser Juvenile Trap (PRJ)

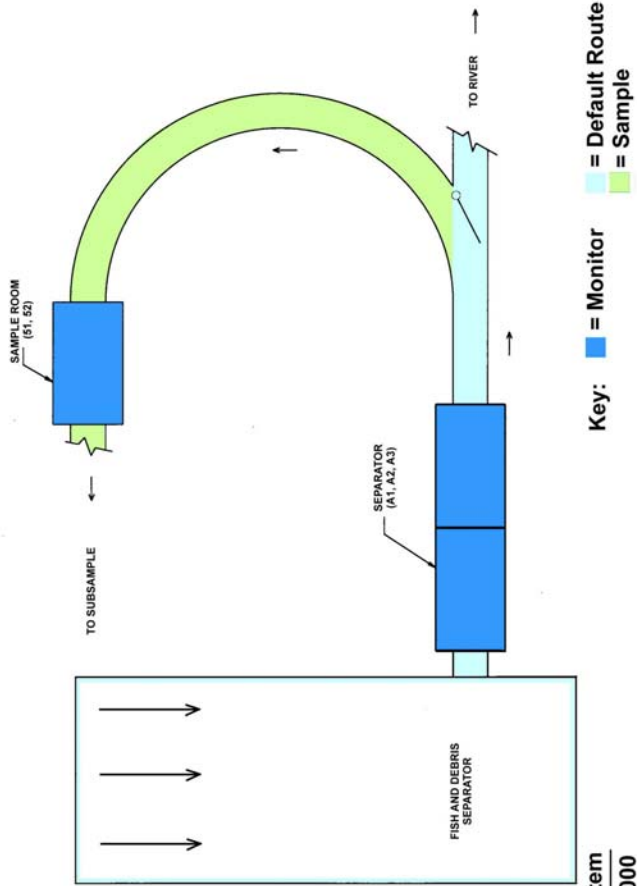

PIT Tag Interrogation System
 Version 2 March 2000
 ISO 134.2 kHz

C14. Site Configuration History

PIT Tag System Codes are assigned by the agency maintaining the monitoring equipment. During 2001, the majority of the monitoring equipment will be maintained by PTOC. Therefore, any questions, changes, or corrections should be addressed to that entity.

PACIFIC STATES MARINE FISHERIES COMMISSION
PIT Tag Database

SITE CONFIGURATION HISTORY
As of 22-Jan-01

Site Name	Monitor Name	-----Coil-----					
		1	2	3	4	5	6
B2A: BONNEVILLE ADULT WA SHORE							
Installed dual ISO/400kHz monitors							
From 22-Jan-01 To Present							
	400 KHZ NORTH	00	02	04			
	400 KHZ SOUTH	10	12	14			
	ISO NORTH	A4	A5				
	ISO SOUTH	B4	B5				
From 7-May-98 To 22-Jan-01							
	NORTH	00	02	04	06		
	SOUTH	10	12	14	16		
	ISO NORTH	AA	BB				
	ISO SOUTH	CC	DD				
B2J: BONNEVILLE 2ND POWERHOUSE							
Installed SAMPLE monitor and coils.							
From 22-Jan-01 To Present							
	SbyC SEPARATOR GATE	A1	A2	A3	A4		
	RIVER EXIT	81	82				
	SbyC EAST TANK	E1	E2				
	SbyC WEST TANK	F1	F2				
	SAMPLE ROOM	51	52				
	SAMPLE / SbyC EXIT	91	92	93			
From 22-Dec-99 To 22-Jan-01							
	SbyC SEPARATOR GATE	A1	A2	A3	A4		
	RIVER EXIT	81	82				
	SbyC EAST TANK	E1	E2				
	SbyC WEST TANK	F1	F2				
	SAMPLE / SbyC EXIT	91	92	93			
From 19-Mar-99 To 22-Dec-99							
	MAIN	02	04	06	08		
From 8-Feb-97 To 19-Mar-99							
	MAIN	02	04	06	08		
From 1-Apr-96 To 8-Feb-97							
	SUBSAMPLE	D0					
BVJ: BONNEVILLE DAM DMS1 SUBSAMPLE							
Single coil subsample monitor. SMP sub-sample in PH 1 DSM channel. Made Main site 3/19/99.							
From 1-Jan-94 To Present							
	SAMPLE ROOM	C0					
From 1-May-92 To 1-Jan-94							
	SAMPLE ROOM	C0					
Site Name	Monitor Name	-----Coil-----					

BVX: BONNEVILLE FLAT PLATE EXP
 Change coil numbers to begin with 01 rather than 00
 From 28-Jul-00 To Present
 FLAT PLATE NW QUAD 04
 FLAT PLATE NE QUAD 03
 FLAT PLATE SE QUAD 01
 FLAT PLATE SW QUAD 02
 From 6-Mar-00 To 26-Jul-00
 FLAT PLATE NW QUAD 03
 FLAT PLATE NE QUAD 02
 FLAT PLATE SE QUAD 00
 FLAT PLATE SW QUAD 01
 From 6-May-96 To 6-Mar-00
 FLAT PLATE 01 02

CFJ: CLARK FLAT ACCLIMATION
 Standardized coil and monitor names.
 From 22-Jan-01 To Present
 EAST RIVER EXIT A1 A2
 WEST RIVER EXIT B1 B2
 From 19-Mar-99 To 22-Jan-01
 RIVER EXIT A 00 02
 RIVER EXIT B 10 12

CHN: CHALLIS DIVERSION NORTH
 Swapped CHN and CHS coils and controllers
 From 15-Sep-91 To Present
 NORTH F1
 From 1-Sep-91 To 15-Sep-91
 NORTH F5

CHS: CHALLIS DIVERSION SOUTH
 Swapped CHN and CHS coils and controllers
 From 15-Sep-91 To Present
 SOUTH F5
 From 1-Sep-91 To 15-Sep-91
 SOUTH F1

CLJ: CLEARWATER RIVER TRAP JUVENILE
 Operated by IDFG.
 From 1-Jan-94 To Present
 MAIN D0 D2
 From 30-Mar-89 To 1-Jan-94
 MAIN D0 D2

ESJ: EASTON ACCLIMATION SITE
 Standardized coil and monitor names.
 From 22-Jan-01 To Present
 EAST RIVER EXIT A1 A2
 WEST RIVER EXIT B1 B2
 From 19-Mar-99 To 22-Jan-01
 RIVER EXIT A 20 22
 RIVER EXIT B 30 32

Site Name	Monitor Name	-----Coil-----					
		1	2	3	4	5	6
GOJ: LITTLE GOOSE DAM JUVENILE							
ISO Installation Complete							
From 10-Jan-00 To Present							
	A-SEPARATOR GATE	A1	A2	A3	A4		
	A-RACEWAY / RIVER EX	11	12	13			
	A-DIVERSION / SbyC G	C1	C2	C3			
	B-SEPARATOR GATE	B1	B2	B3	B4		
	B-RACEWAY / RIVER EX	21	22	23			
	B-DIVERSION / SbyC G	D1	D2	D3			
	SAMPLE ROOM	51	52				
	DIVERSION RIVER EXIT	91	92	93			
From 1-Apr-90 To 20-Jan-00							
	A-SEPARATOR GATE	40	42	44	46		
	A-RACEWAY/EXIT	90	92	94	96		
	A-DIVERSION	A0	A2	A4			
	B-SEPARATOR GATE	48	4A	4C	4E		
	B-RACEWAY/EXIT	98	9A	9C	9E		
	B-DIVERSION	A6	A8	AA			
	SAMPLE ROOM	50	52				
	DIVERSION EXIT	54	56	58	5A		
From 1-Jan-86 To 1-Apr-90							
	UNKNOWN	30	32	34	36	38 3A	
		3C	3E	48	4A	4C 4E	
	A-MAIN	40	42	44	46		
	B-MAIN	90	92	94	96		
	SAMPLE ROOM	A0	A2	A4			
GRA: LOWER GRANITE DAM ADULT							
Installed Dual ISO/400kHz Monitors							
From 22-Jan-01 To Present							
	400 KHZ EAST	00	02	04			
	ISO EAST	A4	A5				
	400 KHZ WEST	10	12	14			
	ISO WEST	B4	B5				
From 1-Feb-95 To 22-Jan-01							
	EAST	00	02	04	06	08	
	WEST	10	12	14	16	18	
From 1-Jan-87 To 1-Feb-95							
	EAST	00	02	08	0A		
	WEST	04	06	0C	0E		
GRJ: LOWER GRANITE DAM JUVENILE							
ISO Installation Complete							
From 3-Jan-00 To Present							
	DIVERSION / SbyC GAT	C1	C2	C3	C4		
	SbyC GATE	D1	D2	D3			
	DIVERSION RIVER EXIT	91	92	93			
	A-SEPARATOR GATE	A1	A2				
	B-SEPARATOR GATE	B1	B2				
	RACEWAY EAST	11	12	13			
	RACEWAY WEST / RIVER	21	22	23			
	SAMPLE TANK	51	52	53			

Site Name	Monitor Name	-----Coil-----					
		1	2	3	4	5	6
GRJ: LOWER GRANITE DAM JUVENILE (continued)							
	From 1-Jan-94 To 20-Jan-00						
	A-SEPARATOR GATE	28	2A				
	B-SEPARATOR GATE	2C	2E				
	RACEWAY EAST	10	12	14	16		
	RACEWAY WEST/EXIT	18	1A	1C	1E		
	DIVERSION 1	36	38	3A			
	DIVERSION 2	30	32	34			
	SUBSAMPLE	20	22	24	26		
	From 25-Mar-88 To 1-Jan-94						
	A-SEPARATOR GATE	28	2A				
	B-SEPARATOR GATE	2C	2E				
	RACEWAY EAST	10	12	14	16		
	RACEWAY WEST/EXIT	18	1A	1C	1E		
	DIVERSION 1	36	38	3A			
	DIVERSION 2	30	32	34			
	SUBSAMPLE	20	22	24	26		
GRX: LOWER GRANITE EXPERIMENTAL							
	Separation by code experimental sub-site.						
	From 27-Feb-96 To Present						
	DIVERSION RIVER GATE	70	72	74	76		
	DIVERSION RIVER EXIT	80	82	84	86		
	DIVERSION HOLD TANK	90	92	94	96		
IMJ: IMNAHA RIVER TRAP JUVENILE							
	Coil ID changed from AA to B8; controller ID unchanged						
	From 1-Jan-95 To Present						
	MAIN		B8				
	From 12-Apr-94 To 1-Jan-95						
	MAIN		AA				
JCJ: Jack Creek							
	Standardized coil and monitor names.						
	From 22-Jan-01 To Present						
	NORTH RIVER EXIT	A1	A2				
	SOUTH RIVER EXIT	B1	B2				
	From 25-Feb-00 To 22-Jan-01						
	RIVER EXIT A	40	42				
	RIVER EXIT B	50	52				
JDJ: JOHN DAY DAM JUVENILE							
	ISO Installation completed.						
	From 16-Dec-99 To Present						
	SbyC SEPARATOR GATE	A1	A2	A3	A4		
	SAMPLE ROOM	51	52	53	54		
	RIVER EXIT	81	82	83	84		
	SbyC GATE	C1	C2	C3	C4		
	SAMPLE / SbyC EXIT	91	92	93	94		
	SbyC EAST TANK	E1	E2				
	SbyC WEST TANK	F1	F2				

Site Name	Monitor Name	-----Coil-----					
		1	2	3	4	5	6
JDJ: JOHN DAY DAM JUVENILE (continued)							
From 2-Mar-98 To 16-Dec-99							
	SBC SEPARATOR	00	02	04	06		
	SUBSAMPLE	70	72	74	76		
	RIVER EXIT ISO	20	21	22	23		
	SBC HOLD TANK	10	12	14	16		
	SAMPLE ROOM RIVER EX	90	91				
	SAMPLE ROOM RIVER EX	94	96				
	SBC HOLD TANK 2	18	1A				
	SBC HOLD TANK 1	1C	1E				
From 6-May-96 To 2-Mar-98							
	GATEWELL 3C	F8					
	SAMPLE ROOM	F4					
	GATEWELL 3B	F6					
From 1-Apr-95 To 6-May-96							
	SAMPLE ROOM	F4					
	SAMPLE BYPASS	F6					
From 1-Jan-92 To 1-Apr-95							
	SAMPLE ROOM	F4					
LMJ: LOWER MONUMENTAL DAM JUVENILE							
ISO installation complete.							
From 26-Jan-00 To Present							
	A-SEPARATOR GATE	A1	A2	A3	A4		
	A-DIVERSION	31	32	33			
	A-RACEWAY	11	12	13			
	A-EXIT	81	82				
	B-SEPARATOR GATE	B1	B2	B3	B4		
	B-DIVERSION	41	42	43			
	B-RACEWAY	21	22	23			
	B-EXIT	01	02				
	DIVERSION RIVER EXIT	91	92	93			
	SAMPLE ROOM	51	52				
From 27-Feb-96 To 22-Jan-00							
	A-SEPARATOR GATE	00	02	04	06		
	A-DIVERSION	20	22	24	26		
	A-RACEWAY	10	12	14	16		
	A-EXIT	30	32	34	36		
	B-SEPARATOR GATE	08	0A	0C	0E		
	B-DIVERSION	28	2A	2C	2E		
	B-RACEWAY	18	1A	1C	1E		
	B-EXIT	38	3A	3C	3E		
	DIVERSION EXIT	40	42	44	46		
	SAMPLE ROOM	48	4A				
From 1-Jan-94 To 27-Feb-96							
	A-SEPARATOR	00	02				
	A-SEPARATOR GATE	04	06				
	A-DIVERSION	20	22	24	26		
	A-RACEWAY	10	12	14	16		
	A-EXIT	30	32	34	36		
	B-SEPARATOR	08	0A				
	B-SEPARATOR GATE	0C	0E				
	B-DIVERSION	28	2A	2C	2E		
	B-RACEWAY	18	1A	1C	1E		
	B-EXIT	38	3A	3C	3E		
	DIVERSION EXIT	40	42	44	46		
	SAMPLE ROOM	48	4A				

Site Name	Monitor Name	-----Coil-----					
		1	2	3	4	5	6
LMJ: LOWER MONUMENTAL DAM JUVENILE (continued)							
From 25-Apr-93 To 1-Jan-94							
	A-SEPARATOR	00	02				
	A-SEPARATOR GATE	04	06				
	A-DIVERSION	20	22	24	26		
	A-RACEWAY	10	12	14	16		
	A-EXIT	30	32	34	36		
	B-SEPARATOR	08	0A				
	B-SEPARATOR GATE	0C	0E				
	B-DIVERSION	28	2A	2C	2E		
	B-RACEWAY	18	1A	1C	1E		
	B-EXIT	38	3A	3C	3E		
	DIVERSION EXIT	40	42	44	46		
	SAMPLE ROOM	48	4A				
MCJ: MCNARY DAM JUVENILE							
ISO Installation complete.							
From 21-Jan-00 To Present							
	A-SEPARATOR GATE	A1	A2	A3	A4		
	A-SUBSAMPLE	61	62	63			
	A-RACEWAY	11	12	13			
	A-DIVERSION	31	32	33			
	RIVER-1 EXIT	81	82	83	84		
	B-SEPARATOR GATE	B1	B2	B3	B4		
	B-SUBSAMPLE	71	72	73			
	B-RACEWAY	21	22	23			
	B-DIVERSION	41	42	43			
	RIVER-2 EXIT	91	92	93			
	SAMPLE ROOM	51	52				
From 2-Mar-98 To 22-Jan-00							
	A-SEPARATOR GATE	00	02	50	52		
	A-SUBSAMPLE	30	32	34			
	A-RACEWAY	10	12	14	16		
	A-DIVERSION	20	22	24	26		
	RIVER-1	40	42	44	46		
	B-SEPARATOR GATE	08	0A	54	56		
	B-SUBSAMPLE	36	38	3A			
	B-RACEWAY	18	1A	1C	1E		
	B-DIVERSION	28	2A	2C	2E		
	RIVER-2	48	4A	4C	4E		
	SAMPLE ROOM	3C	3E				
	B-RACEWAY ISO	A1	A2	A3	A4		
	RIVER-2 ISO	B1	B2	B3	B4		
	RIVER-1 ISO	C1	C2	C3	C4		
	400 Test	80	82	84	86		
From 27-Feb-96 To 2-Mar-98							
	A-SEPARATOR GATE	00	02	50	52		
	A-SUBSAMPLE	30	32	34			
	A-RACEWAY	10	12	14	16		
	A-DIVERSION	20	22	24	26		
	RIVER-1	40	42	44	46		
	B-SEPARATOR GATE	08	0A	54	56		
	B-SUBSAMPLE	36	38	3A			
	B-RACEWAY	18	1A	1C	1E		
	B-DIVERSION	28	2A	2C	2E		
	RIVER-2	48	4A	4C	4E		
	SAMPLE ROOM	3C	3E				

Site Name	Monitor Name	-----Coil-----					
		1	2	3	4	5	6
MCJ: MCNARY DAM JUVENILE (continued)							
From 1-Jan-94 To 27-Feb-96							
	A-SEPARATOR	50	52				
	A-SEPARATOR GATE	00	02				
	A-SUBSAMPLE	30	32	34			
	A-RACEWAY	10	12	14	16		
	A-DIVERSION	20	22	24	26		
	A-RIVER	40	42	44	46		
	B-SEPARATOR	54	56				
	B-SEPARATOR GATE	08	0A				
	B-SUBSAMPLE	36	38	3A			
	B-RACEWAY	18	1A	1C	1E		
	B-DIVERSION	28	2A	2C	2E		
	B-RIVER	48	4A	4C	4E		
	SAMPLE ROOM	3C	3E				
	UNKNOWN	01	07	09			
From 1-Jan-86 To 1-Jan-94							
	A-MAIN	68	6A	6C	6E		
	B-MAIN	60	62	64	66		
	A-SUB	70	72	74	76		
	SAMPLE ROOM	80	82				
MCX: MCNARY JUVENILE EXPERIMENTAL							
Summarize distinguishing features of the new configuration							
From 20-Feb-98 To Present							
	ISO B-RACEWAY	A1	A2	A3	A4		
	ISO RIVER-1	B1	B2	B3	B4		
PRJ: PROSSER JUVENILE (CHAND DIV)							
Initial ISO Configuration							
From 10-Nov-99 To Present							
	SEPARATOR / SAMPLE	A1	A2	A3			
	SAMPLE ROOM EXIT	51	52				
From 1-Jan-94 To 10-Nov-99							
	SEPARATOR	C8	CA	CC	CE		
	SAMPLE ROOM	C4	C6				
From 25-Apr-89 To 1-Jan-94							
	SEPARATOR	C8	CA	CC	CE		
	SAMPLE ROOM	C4	C6				
RFA: REDFISH LK CR TRAP JUVENILE A							
Redfish Lake Creek Trap operated by IDFG.							
From 13-Apr-95 To Present							
	RIVER EXIT	F3					
RFB: REDFISH LK CR TRAP JUVENILE B							
Redfish Lake Creek Trap (B) operated by IDFG							
From 13-Apr-95 To Present							
	RIVER EXIT	F5					
ROZ: ROSA DAM JUVENILE							
Dates are accurate; equipment configuration must be established							
From 26-Mar-92 To 30-May-92							
	MAIN	C0					

Site Name	Monitor Name	-----Coil-----					
		1	2	3	4	5	6
RPJ: RAPID RIVER VOLITIONAL RELEASE							
Rapid River Hatchery Outfall							
From 19-Apr-99 To Present							
	UNDERFLOW ORIFICE	00	01	02			
	OVERFLOW DOWNSTREAM	03	04	05	06		
	OVERFLOW UPSTREAM	07	08	09	0A		
RRJ: ROCKY REACH DAM JUVENILE							
2000 Update. Site converted to ISO 134.2kHz exceptfor coils							
77 and 88 which are 134.2kHz Non-ISO.							
From 25-Feb-00 To Present							
	SURFACE COLLECTOR 1	11	22	33	44		
	SURF COLL 2/UNIT 1,2	05	06				
	BACKUP GATEWELL/SURF	77	88				
	JUV COLLECTION FACIL	55					
From 26-Apr-99 To 25-Feb-00							
	SURFACE COLLECTOR 24	11	22	33	44		
	GATEWELL SAMPLE	05	06	A0	A2	A4 A6	
	BACKUP GATEWELL/SURF	77	88				
	SAMPLE	AA					
From 11-Mar-98 To 26-Apr-99							
	SURFACE COLLECTOR 24	11	22	33	44		
	GATEWELL SAMPLE	A0	A2	A4	A6		
	BACKUP GATEWELL/SURF	77	88				
From 4-Apr-97 To 11-Mar-98							
	SURFACE COLLECTOR 24	11	22	33	44		
	GATEWELL COLLECTION	05	06				
	BACKUP GATEWELL/SURF	77	88				
From 10-Apr-96 To 4-Apr-97							
	SURFACE COLLECTOR 24	11	22	33	44		
	GATEWELL COLLECTOR 6	55	88				
	SURFACE COLLECTOR 6	66	77				
SAJ: SALMON RIVER TRAP JUVENILE							
Salmon River Juvenile trap operated by IDFG.							
From 1-Jan-94 To Present							
	MAIN		D8				
From 28-Mar-93 To 1-Jan-94							
	MAIN		D8				
SNJ: SNAKE RIVER TRAP JUVENILE							
Snake River Juvenile Trap operated by IDFG.							
From 1-Jan-94 To Present							
	MAIN		D4	D6			
From 23-Mar-89 To 1-Jan-94							
	MAIN		D4	D6			
SSJ: SUNNYSIDE JUVENILE							
Dates and coil/controller data accurate; monitor name must							
be researched							
From 11-Apr-91 To 5-Jun-91							
	MAIN		FF				
SUJ: SULLIVAN DAM JUVENILE							
Converted to ISO 1999.							
From 1-Jan-94 To Present							
	SAMPLE ROOM		AA				

Site Name	Monitor Name	-----Coil-----					
		1	2	3	4	5	6
TMJ: THREE MILE FALLS DAM							
ISO Installation (ODFW) 2-FS2001 Units							
From 6-Mar-00 To Present							
	RIVER EXIT	10	11				
From 19-Mar-99 To 6-Mar-00							
	RIVER EXIT	10					
TST: Test Site							
THIS SITE CODE USED FOR PSMFC TESTING PURPOSES							
From 22-Apr-00 To Present							
	TEST MONITOR 1	01	02	03	04	05	06
	TEST MONITOR 2	07	08	09	0A	0B	0C
TWX: ESTUARY TOWED ARRAY EXPERIMENT							
ISO INSTALLATION -- ONE 36 INCH COIL							
From 30-Mar-00 To Present							
	RIVER EXIT	00					
From 26-Apr-99 To 30-Mar-00							
	RIVER EXIT	9E					
	RIVER EXIT	36					
	RIVER EXIT	00	02				
	RIVER EXIT	5A					
From 1-Mar-98 To 26-Apr-99							
	RIVER EXIT	9E					
	RIVER EXIT	36					
	RIVER EXIT	5A					
From 13-Apr-95 To 1-Mar-98							
	RIVER EXIT	20	22				
	RIVER EXIT	10	12				
WAJ: WANAPUM DAM JUVENILE (G-DIP)							
Date and coil/controller data accurate; monitor name must be verified							
From 28-Apr-94 To Present							
	MAIN	F0					
WPJ: WAPATO DIVERSION JUVENILE							
Dates and coil/controller data are accurate; monitor name must be reviewed							
From 8-May-91 To 5-Jun-91							
	MAIN	FB					
Y1J: YAKIMA RIVER TRAP JUVENILE							
Dates and coil/controller data are correct; monitor name must be verified							
From 4-May-90 To 11-Jun-90							
	MAIN	B8					

Appendix D. GIS Maps

D1. State of Idaho



D3. State of Washington

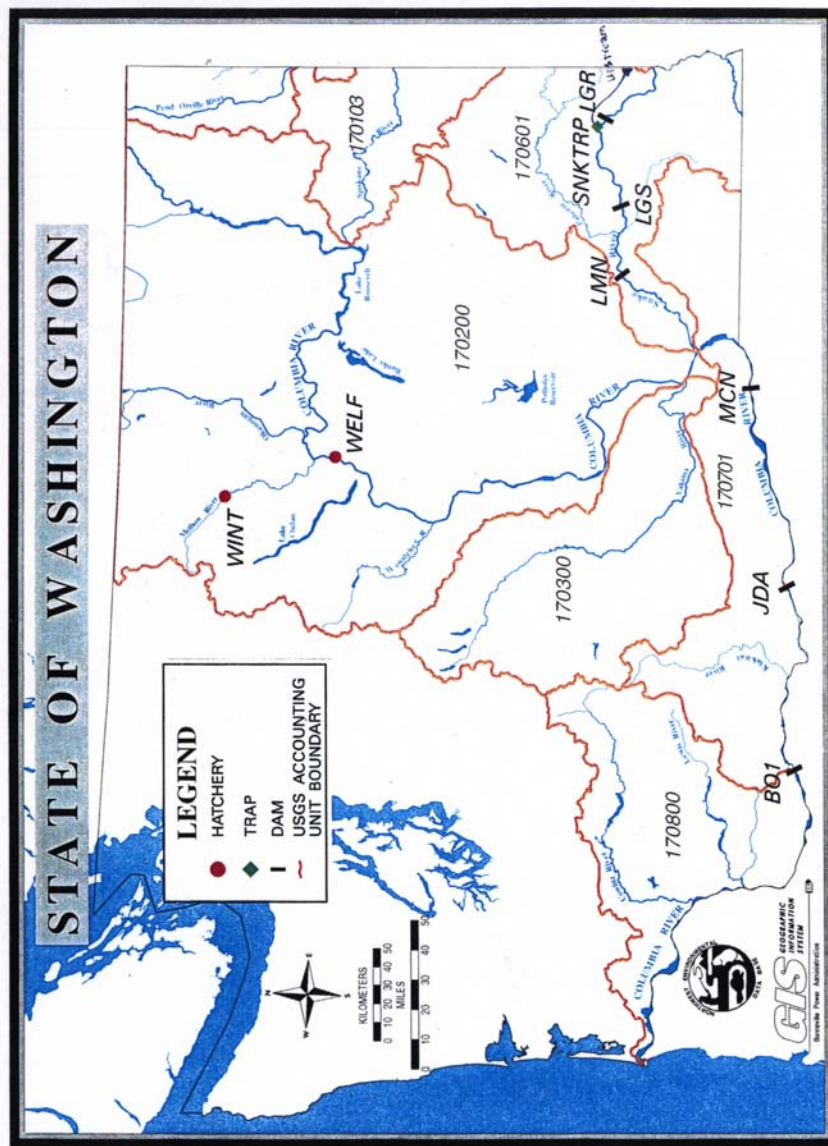

This Page Intentionally Left Blank

This Page Intentionally Left Blank

Appendix E. Perpetual Day-of-Year Calendars

E1. Perpetual Day-of-Year Calendar — Non-Leap Years

Day	Jan	Feb	Mar	Apr	May	June	July	Aug	Sep	Oct	Nov	Dec	Day
1	001	032	60	91	121	152	182	213	244	274	305	335	1
2	002	033	061	092	122	153	183	214	245	275	306	336	2
3	003	034	062	093	123	154	184	215	246	276	307	337	3
4	004	035	063	094	124	155	185	216	247	277	308	338	4
5	005	036	064	095	125	156	186	217	248	278	309	339	5
6	006	037	065	096	126	157	187	218	249	279	310	340	6
7	007	038	066	097	127	158	188	219	250	280	311	341	7
8	008	039	067	098	128	159	189	220	251	281	312	342	8
9	009	040	068	099	129	160	190	221	252	282	313	343	9
10	010	041	069	100	130	161	191	222	253	283	314	344	10
11	011	042	070	101	131	162	192	223	254	284	315	345	11
12	012	043	071	102	132	163	193	224	255	285	316	346	12
13	013	044	072	103	133	164	194	225	256	286	317	347	13
14	014	045	073	104	134	165	195	226	257	287	318	348	14
15	015	046	074	105	135	166	196	227	258	288	319	349	15
16	016	047	075	106	136	167	197	228	259	289	320	350	16
17	017	048	076	107	137	168	198	229	260	290	321	351	17
18	018	049	077	108	138	169	199	230	261	291	322	352	18
19	019	050	078	109	139	170	200	231	262	291	323	353	19
20	020	051	079	110	140	171	201	232	263	293	324	354	20
21	021	052	080	111	141	172	202	233	264	294	325	355	21
22	022	053	081	112	142	173	203	234	265	295	326	356	22
23	023	054	082	113	143	174	204	235	266	296	327	357	23
24	024	055	083	114	144	175	205	236	267	297	328	358	24
25	025	056	084	115	145	176	206	237	268	298	329	359	25
26	026	057	085	116	146	177	207	238	269	299	330	360	26
27	027	058	086	117	147	178	208	239	270	300	331	361	27
28	028	059	087	118	148	179	209	240	271	301	332	362	28
29	029		088	119	149	180	210	241	272	302	333	363	29
30	030		089	120	150	181	211	242	273	303	334	364	30
31	031		090		151		212	243		304		365	31

E2. Perpetual Day-of-Year Calendar — Leap Years

Day	Jan	Feb	Mar	Apr	May	June	July	Aug	Sep	Oct	Nov	Dec	Day
1	001	032	061	092	122	153	183	214	245	275	306	336	1
2	002	033	062	093	123	154	184	215	246	276	307	337	2
3	003	034	063	094	124	155	185	216	247	277	308	338	3
4	004	035	064	095	125	156	186	217	248	278	309	339	4
5	005	036	065	096	126	157	187	218	249	279	310	340	5
6	006	037	066	097	127	158	188	219	250	280	311	341	6
7	007	038	067	098	128	159	189	220	251	281	312	342	7
8	008	039	068	099	129	160	190	221	252	282	313	343	8
9	009	040	069	100	130	161	191	222	253	283	314	344	9
10	010	041	070	101	131	162	192	223	254	284	315	345	10
11	011	042	071	102	132	163	193	224	255	285	316	346	11
12	012	043	072	103	133	164	194	225	256	286	317	347	12
13	013	044	073	104	134	165	195	226	257	287	318	348	13
14	014	045	074	105	135	166	196	227	258	288	319	349	14
15	015	046	075	106	136	167	197	228	259	289	320	350	15
16	016	047	076	107	137	168	198	229	260	290	321	351	16
17	017	048	077	108	138	169	199	230	261	291	322	352	17
18	018	049	078	109	139	170	200	231	262	291	323	353	18
19	019	050	079	110	140	171	201	232	263	293	324	354	19
20	020	051	080	111	141	172	202	233	264	294	325	355	20
21	021	052	081	112	142	173	203	234	265	295	326	356	21
22	022	053	082	113	143	174	204	235	266	296	327	357	22
23	023	054	083	114	144	175	205	236	267	297	328	358	23
24	024	055	084	115	145	176	206	237	268	298	329	359	24
25	025	056	085	116	146	177	207	238	269	299	330	360	25
26	026	057	086	117	147	178	208	239	270	300	331	361	26
27	027	058	087	118	148	179	209	240	271	301	332	362	27
28	028	059	088	119	149	180	210	241	272	302	333	363	28
29	029	060	089	120	150	181	211	242	273	303	334	364	29
30	030		090	121	151	182	212	243	274	304	335	365	30
31	031		091		152		213	244		305		366	31

This Page Intentionally Left Blank

Appendix F. PTAGIS Database Structure

F1. Overview of PTAGIS DBMS Schema

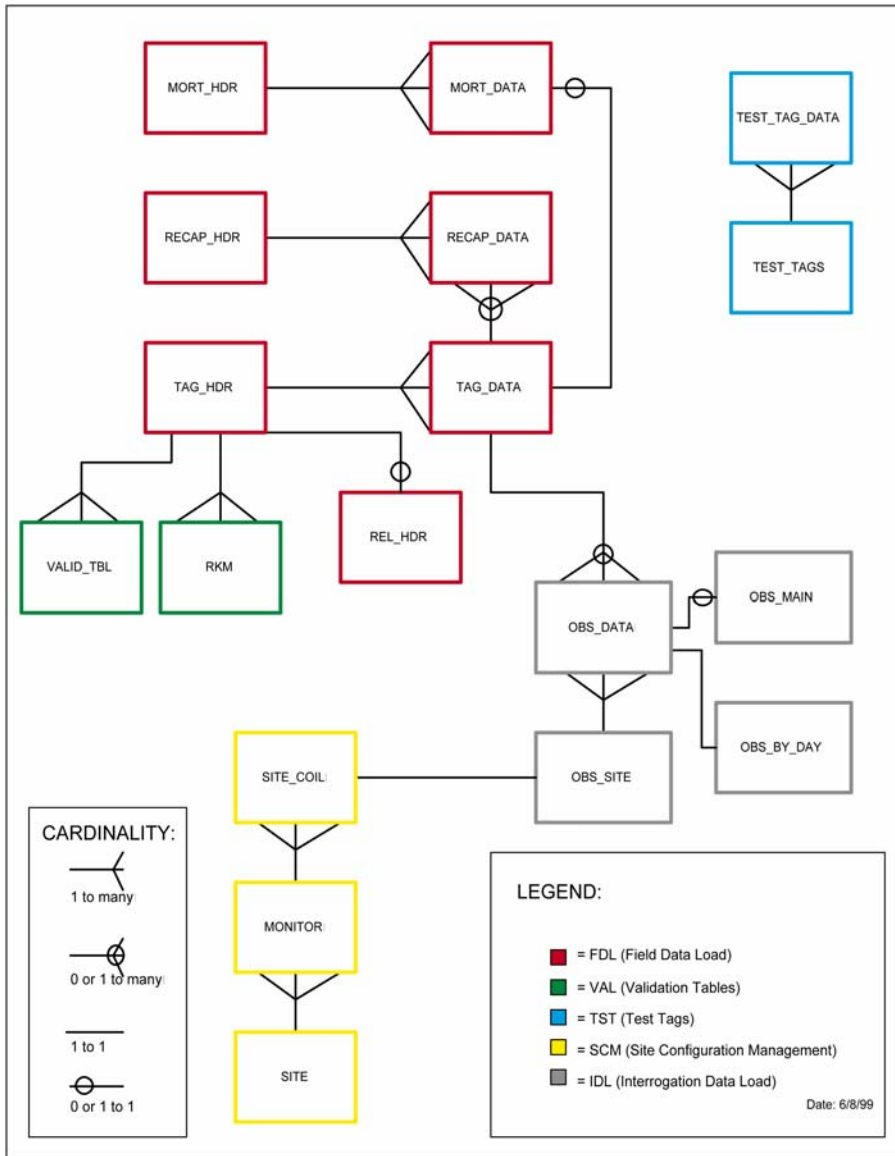

F2. Field Data Load (FDVL) Sub-Schema

The PIT Tag Operations Center (PTOC) runs processes that incorporate the "raw" Tagging and Release Information Files, as defined in this Columbia River Basin PIT Tag Information System Data Source Input Specification (a.k.a., the SpecDoc). PTOC refers to these processes as the FDL processes. These processes are currently initiated manually in order to assure that the process does not over-load system resources, does not interfere with other PTAGIS processing and to assure successful completion of the load event. The following describes the main tables that are updated during the operation of the FDL processes.

FDVL Tables: tag_data, tag_hdr, mort_data, mort_hdr, recap_data, recap_hdr

Table Functions:

tag_data:

The tag_data table contains one record per fish that is released in the Columbia River drainage. This record is contained in a Tagging and Release Information File (Tagging File) that is submitted by PTAGIS system users. The tag_file field in the tag_data table contains a reference to the Tagging and Release Information File submitted by PTAGIS users. There are one or more tag_data records for each tag_file.

Special Notes:

Recapture and Mortality information are assigned to individual fish using the flags attribute (See "

Conditional Comments (Flag Codes)" on page 24).

If a fish is marked with an RE Flag Code, then this fish record is written to the recap_data table and the tag_header information associated with this tag_data record is loaded to the recap_hdr table (if it does not exist there already). Likewise, if a fish is marked with any of the mortality flag codes, (e.g., M, MB, MK, MS, SM), then a mort_data record is created with this tag_id and a corresponding mort_hdr record is created based upon associated information.

Fish that die during recapture must be reported with flag codes of RE and M (this means recapture, mortality). The tag from this fish cannot be used again. Records with RE M flags will generate corresponding records in the mort_hdr, mort_data, recap_hdr and recap_data tables.

Adult fish that are recaptured at hatcheries should have RE RF flag codes. The RE flag code will assure that a record is inserted into the recap_hdr and recap_data tables. The RF flag will be used to report the adult return in the "Final Disposition Analysis" reports that will provide life-cycle information for each tagged fish.

tag_hdr:

Each tagging file that is submitted to PTAGIS generates one tag_hdr record. This record contains information related to all fish contained in the Tagging File.

mort_data:

Fish records in a Tagging File that are marked with a mortality flag code (M, MB, MK, MS, SM) generate a single mort_data record. Tags from fish that died after marking and prior to release can be reused. In this case, the tag_id for the fish that died should either be "dotted out" or removed from the Tagging File.

mort_hdr:

One mort_hdr record is created for a collection of one or more mort_data records. The mort_hdr record is "cloned" from the tag_hdr record in a Tagging File.

recap_data:

A recap_data record is generated for tagging records that are marked with an "RE" flag code. A fish may be recaptured many times, so there may be many recap_data records for the same tag_code.

recap_hdr:

One recap_hdr record is created for a collection of one or more recap_data records generated from the same Tagging File. The recap_hdr record is "cloned" from the tag_hdr record created from information in the Tagging File.

Table Definitions:

Name: tag_data

```
Owner:                pittag
Created:              30-sep-1998 13:57:09
Location:             db3
Type:                 user table
Version:              OI2.0
Page size:            2048
Cache priority:       0
Alter table version:  0
Alter table totwidth: 164
Row width:            164
Number of rows:       4798229
Storage structure:    btree with unique keys
Compression:         none
Duplicate Rows:       not allowed
Number of pages:      589083
Overflow data pages:  0
```

Journaling: enabled after the next checkpoint
 Base table for view: yes
 Permissions: yes
 Integrities: none
 Optimizer statistics: yes; see avg count below, more info in the iistats catalog

Column Information:

Column Name	Type	Length	Nulls	Defaults	Key Seq	Avg Count Per Value
migr_yr	char	2	yes	null		
tag_file	char	15	yes	null		154.3
tag_id	char	15	yes	null	1	unique
seq_no	integer	4	yes	null		437.3
t_species	char	2	yes	null		
t_run	char	2	yes	null		
t_rear_type	char	2	yes	null		
brd_yr	char	3	yes	null		
wt	float	8	yes	null		
length	integer	4	yes	null		
length_type	char	2	yes	null		
t_cksum	char	2	yes	null		
rel_var	char	5	yes	null		
rel_v_time	date		yes	null		
flags	varchar	11	yes	null		
mort_flag	char	2	yes	null		
recap_v_n	char	1	yes	null		
tag_rem	varchar	50	yes	null		

Secondary indexes:

Index Name	Structure	Keyed On
x_tagid	btree	tag_id
xtag_file	btree	tag_file

Name: tag_hdr

Owner: pittag
Created: 30-sep-1998 13:27:31
Location: db1
Type: user table
Version: OT2.0
Page size: 2048
Cache priority: 0
Alter table version: 0
Alter table totwidth: 427
Row width: 427
Number of rows: 27180
Storage structure: btree
Compression: none
Duplicate Rows: allowed
Number of pages: 7772
Overflow data pages: 0
Journaling: enabled after the next checkpoint
Base table for view: yes
Permissions: yes
Integrities: none
Optimizer statistics: yes; see avg count below, more info in the iistats catalog

Column Information:

Column Name	Type	Length	Nulls	Defaults	Key Seq	Avg Count Per Value
migr_yr	char	2	yes	null		
file_id	char	15	yes	null	1	unique
tag_site	char	8	yes	null		
tag_date	date		yes	null		
nfish	integer	4	yes	null		
mort_no	integer	4	yes	null		
species	char	2	yes	null		
run	char	2	yes	null		
rear_type	char	2	yes	null		
hatchery	char	4	yes	null		
stock	char	15	yes	null		
brood_yr	char	2	yes	null		
raceway	char	10	yes	null		
capture_meth	char	8	yes	null		
tag_temp	float	8	yes	null		
tag_meth	char	4	yes	null		
org	char	6	yes	null		
coord_id	char	3	yes	null		
tagger	char	20	yes	null		
rel_file	char	15	yes	null		
rel_date	date		yes	null		
rel_num	integer	4	yes	null		
rel_site	char	8	yes	null		102.3
rel_temp	float	8	yes	null		
river_km	char	27	yes	null		
epa_reach	char	8	yes	null		
transp_dur	char	8	yes	null		
transp_type	char	20	yes	null		
water_temp	float	8	yes	null		
assoc_mark	char	30	yes	null		
close_date	date		yes	null		
tag_session	varchar	100	yes	null		
mon_rel_y_n	char	1	yes	null		

Secondary indexes:

Index Name	Structure	Keyed On
xtaghdr_relsite	btree	rel_site, file_id

Name: recap_data

Owner: pittag
Created: 30-sep-1998 13:27:04
Location: dbl
Type: user table
Version: OI2.0
Page size: 2048
Cache priority: 0
Alter table version: 0
Alter table totwidth: 165
Row width: 165
Number of rows: 161142
Storage structure: btree
Compression: none
Duplicate Rows: allowed
Number of pages: 22985
Overflow data pages: 0
Journaling: enabled after the next checkpoint
Base table for view: yes
Permissions: yes
Integrities: none
Optimizer statistics: yes; see avg count below, more info in the iistats catalog

Column Information:

Column Name	Type	Length	Nulls	Defaults	Key Seq	Avg Count Per Value
tag_id	char	15	yes	null	2	unique
recap_file	char	12	yes	null	1	15.8
orig_tagfile	char	15	yes	null		
re_migr_yr	char	2	yes	null		
re_t_chksum	char	2	yes	null		
re_seq_no	integer	4	yes	null		
re_length_type	char	2	yes	null		
re_length	integer	4	yes	null		
re_wt	float	8	yes	null		
re_t_species	char	1	yes	null		
re_t_run	char	1	yes	null		
re_t_rear_type	char	1	yes	null		
re_brd_yr	char	3	yes	null		
re_rel_var	char	5	yes	null		
re_rel_v_time	date		yes	null		
re_flags	char	11	yes	null		
re_tag_rem	char	50	yes	null		

Secondary indexes:

Index Name	Structure	Keyed On
retagx	btree	tag_id

Name: recap_hdr

Owner: pittag
Created: 30-sep-1998 13:31:05
Location: db1
Type: user table
Version: OT2.0
Page size: 2048
Cache priority: 0
Alter table version: 0
Alter table totwidth: 405
Row width: 405
Number of rows: 10354
Storage structure: btree
Compression: none
Duplicate Rows: allowed
Number of pages: 2951
Overflow data pages: 0
Journaling: enabled after the next checkpoint
Base table for view: yes
Permissions: yes
Integrities: none
Optimizer statistics: yes; see avg count below, more info in the iistats catalog

Column Information:

Column Name	Type	Length	Nulls	Defaults	Key Seq	Avg Count Per Value
re_migr_yr	char	2	yes	null		
recap_file	char	12	yes	null		unique
re_site	char	6	yes	null	1	91.3
re_date	date		yes	null		
re_nfish	integer	4	yes	null		
re_mort_no	integer	4	yes	null		
re_species	char	1	yes	null		
re_run	char	1	yes	null		
re_rear_type	char	1	yes	null		
re_hatchery	char	4	yes	null		
re_stock	char	15	yes	null		
re_brood_yr	char	2	yes	null		
re_raceway	char	15	yes	null		
re_capture_meth	char	8	yes	null		
re_tag_temp	float	8	yes	null		
re_tag_meth	char	4	yes	null		
re_org	char	6	yes	null		
re_coord_id	char	3	yes	null	2	182.5
re_tagger	char	20	yes	null		
re_rel_file	char	12	yes	null		
re_rel_date	date		yes	null		
re_rel_site	char	6	yes	null		
re_rel_temp	float	8	yes	null		
re_river_km	char	20	yes	null		
re_epa_reach	char	8	yes	null		
re_transp_dur	char	8	yes	null		
re_transp_type	char	20	yes	null		
re_water_temp	float	8	yes	null		
re_assoc_mark	char	30	yes	null		
re_close_date	date		yes	null		
re_session	varchar	100	yes	null		

Secondary indexes:

Index Name	Structure	Keyed On
refilex	btree	recap_file

Name: mort_data

Owner: pittag
Created: 30-sep-1998 13:32:18
Location: db1
Type: user table
Version: OT2.0
Page size: 2048
Cache priority: 0
Alter table version: 0
Alter table totwidth: 208
Row width: 208
Number of rows: 80164
Storage structure: btree
Compression: none
Duplicate Rows: allowed
Number of pages: 11201
Overflow data pages: 0
Journaling: enabled after the next checkpoint
Base table for view: yes
Permissions: yes
Integrities: none
Optimizer statistics: yes; see avg count below, more info in the iistats catalog

Column Information:

Column Name	Type	Length	Nulls	Defaults	Key Seq	Avg Count Per Value
m_file	char	15	yes	null		62.1
tag_file	char	15	yes	null	1	11.2
m_tagid	char	15	yes	null		unique
m_cksm	char	2	yes	null		
migr_yr	char	2	yes	null		
m_seq_no	integer	4	yes	null		
tag_lgth	integer	4	yes	null		
tag_wt	float	8	yes	null		
mrt_lgth	float	8	yes	null		
mrt_wt	float	8	yes	null		
org	char	6	yes	null		
coord_id	char	3	yes	null		
tag_rel_site	char	6	yes	null		
tag_rel_date	date		yes	null		
mort_date	date		yes	null		
species	char	1	yes	null		
run	char	1	yes	null		
rear_type	char	1	yes	null		
flag_code	varchar	11	yes	null		
m_rem	varchar	50	yes	null		

Secondary indexes:

Index Name	Structure	Keyed On
xm_file	btree	m_file
xm_tagid	btree	m_tagid

Name: mort_hdr

Owner: pittag
Created: 30-sep-1998 13:22:26
Location: db1
Type: user table
Version: OT2.0
Page size: 2048
Cache priority: 0
Alter table version: 0
Alter table totwidth: 198
Row width: 198
Number of rows: 1238
Storage structure: btree
Compression: none
Duplicate Rows: allowed
Number of pages: 189
Overflow data pages: 0
Journaling: enabled after the next checkpoint
Base table for view: yes
Permissions: yes
Integrities: none
Optimizer statistics: yes; see avg count below, more info in the iistats catalog

Column Information:

Column Name	Type	Length	Nulls	Defaults	Key Seq	Avg Count Per Value
mort_file	char	15	yes	null	1	unique
m_file_date	date		yes	null		
coll_site	char	6	yes	null		
river_km	char	27	yes	null		
m_capt_meth	char	6	yes	null		
cap_org	char	6	yes	null		
m_coord_id	char	3	yes	null		
m_close_date	date		yes	null		
proj_mess	varchar	100	yes	null		

Secondary indexes: none

F3. Interrogation Data Load (IDL) Sub-Schema

The PTOC runs processes that incorporate the "raw" Interrogation Files, as defined in the Spec Doc. PTOC refers to these processes as IDL processes. The IDL processes are initiated automatically at 00:05, 06:05, and 12:05 daily. The following describes the main tables that are updated during the IDL processes.

IDL Tables: **obs_data**, **obs_site**, **obs_main**, **obs_by_day**

Table Purpose:

obs_data

Each row in the `obs_data` table corresponds to one "fish" record in a 'raw' interrogation file (either the new "MULTIMON" file type, or the traditional "INTERROGATION" file type). If a single fish generates 20 interrogation records, then 20 fish records will be inserted to the `obs_data` table.

"Fish" records are distinguished from "test tags" during the load process of an interrogation file by probing the `test_tags` table for a matching `tag_id`. If a match is found in the `test_tags` table, then the corresponding interrogation record is not loaded into the `obs_data` table, but instead is loaded into the `test_tag_data` table. Other records in an interrogation file that are not `test_tag` records or fish records are diagnostic of the interrogation system at the site, or descriptive of the site itself.

As IDL processes fish records from interrogation files, it not only inserts a new record to the `obs_data` table, but will update or insert new records into the `obs_site` table, `obs_main` table and the `obs_by_day` table. These tables contain a single summary record for each distinct fish record (`tag_id`) as appropriate.

obs_site

The `obs_site` table contains a single record for each fish seen at each interrogation site. For example if the fish was seen at the Snake Trap (SNJ), Little Goose (GOJ), Bonneville Powerhouse 2 (B2J) and at the Lower Granite Adult Ladder, then the `obs_site` table will contain 4 records with the unique `tag_id` of the fish. These records contains the first interrogation date and time of this fish at associated site and the coil identifier (location within the site) where this fish was seen. In addition, it contains the last interrogation date and time that this fish was seen at this site in addition to the last coil identifier that 'saw' this fish. In addition, a count of the total number of 'coil hits' is accumulated that indicates the number of times this fish was seen on any coil. If a fish was seen on coil 01, coil 02, on coil 01 again and finally on coil 03, then the `intrgn_count` will record four coil hits for this fish at this site.

obs_main

There are zero or one records in the `obs_main` table for any `tag_id` record that exists in the `tag_data` table or `obs_data` table. If the fish is never interrogated at a "Main Site", there will be no matching record in `obs_main`. If the fish is seen at one or more main interrogation sites in the river system, there will be exactly one record for this fish in the `obs_main` table.

The advantage of this summary table is that it records only the first interrogation of the fish at any "Main Site". This table is maintained in order to provide faster reporting of "First Obs Main" reports. The First Obs Main reports show only the first interrogation of a fish as it migrates down stream. This allows the user to determine what percent of a fish release was seen first, for example, at Lower Granite, Little Goose, Lower Monumental, Bonneville, etc. The PIT Tag Steering Committee determines which sites are designated as "Main Sites". This designation is stored in the PTAGIS database in the Site Configuration Management Schema of PTAGIS.

In addition to tracking the first main site that the fish was seen at the `obs_main` table keeps track of the last main site that a fish was seen at. The first time that the fish was seen, the first obs site and the last obs site (and corresponding date and time stamps) are set to the same value. When the fish is seen at subsequent main sites, the record for this fish is updated to reflect the last place and time that this fish was seen.

obs_by_day

The obs_by_day table contains a single record for each fish seen at each site. This summary table contains only the date that the fish was first seen at this site; it does not include the time stamp. If the fish was seen at 23:57 on May 31, 1998 and then at 00:14 on June 1, 1998 at Lower Granite Dam then the obs_by_day table contains a single record that shows this fish on May 31, 1998. This table also contains the name of the interrogation file where this fish was first seen on this date.

This table is used to generate the obs_by_day reports. The obs_by_day reports list the number of fish seen at an interrogation site, by species, run and rearing_type on the given day.

Table Definitions:

Name: obs_data

```
Owner:                pittag
Created:              30-sep-1998 13:32:22
Location:            db6,
                   db5,
                   db4
Type:                user table
Version:             0I2.0
Page size:          2048
Cache priority:     0
Alter table version: 0
Alter table totwidth: 92
Row width:         92
Number of rows:    18581463
Storage structure: btree
Compression:       none
Duplicate Rows:    not allowed
Number of pages:   1764958
Overflow data pages: 0
Journaling:        disabled
Base table for view: yes
Permissions:       yes
Integrities:       none
Optimizer statistics: yes; see avg count below, more info in the iistats catalog
```

Column Information:

Column Name	Type	Length	Nulls	Defaults	Key Seq	Avg Per Value
obs_date	date		yes	null	3	2.0
obs_site	char	3	yes	null	1	428280.8
cnfg_seq_nbr	integer	4	no	yes		
tag_id	char	15	yes	null	2	8.4
cksm	char	2	yes	null		
contr	char	2	yes	null		
nreads	integer	4	yes	null		
coil1	char	2	yes	null		
coil2	char	2	yes	null		
coil3	char	2	yes	null		
coil4	char	2	yes	null		
obs_file	char	15	yes	null		459.0
obs_first	char	1	yes	null		
obs_flag2	char	1	yes	null		
obs_flag3	char	1	yes	null		
notfnd	char	1	yes	null		
cksum_ign	char	1	yes	null		
tagid_mod	char	1	yes	null		
anomalie_nbr	integer	4	no	yes		

Secondary indexes:

Index Name	Structure	Keyed On
o_d_x1	btree	obs_date

```

obtagx          btree      tag_id
xobs_file       btree      obs_file

```

Name: obs_site

```

Owner:          pittag
Created:        30-sep-1998 13:22:30
Location:       db3
Type:           user table
Version:        OI2.0
Page size:      2048
Cache priority: 0
Alter table version: 0
Alter table totwidth: 88
Row width:      88
Number of rows: 3108105
Storage structure: btree
Compression:    none
Duplicate Rows: not allowed
Number of pages: 287645
Overflow data pages: 0
Journaling:     enabled after the next checkpoint
Base table for view: yes
Permissions:    yes
Integrities:    none
Optimizer statistics: yes; see avg count below, more info in the iistats catalog

```

Column Information:

Column Name	Type	Length	Nulls	Defaults	Key Seq	Avg Count Per Value
tag_id	char	15	yes	null	2	1.5
obs_site	char	3	yes	null	1	77938.4
intrgn_count	integer	4	no	yes		10971.9
first_obs_date	date		yes	null	3	unique
first_cnfg_seq_nbr	integer	4	no	yes		
first_coil	char	2	no	yes		
first_obs_file	char	12	yes	null		
last_obs_date	date		yes	null		
last_cnfg_seq_nbr	integer	4	no	yes		
last_coil	char	2	no	yes		
last_obs_file	char	12	yes	null		88.8

Secondary indexes:

Index Name	Structure	Keyed On
o_s_x1	btree	intrgn_count
o_s_x2	btree	last_obs_file
o_s_x3	btree	tag_id

Name: obs_main

Owner: pittag
Created: 30-sep-1998 14:06:31
Location: db4
Type: user table
Version: OI2.0
Page size: 2048
Cache priority: 0
Alter table version: 0
Alter table totwidth: 88
Row width: 88
Number of rows: 1874815
Storage structure: btree with unique keys
Compression: none
Duplicate Rows: not allowed
Number of pages: 148694
Overflow data pages: 0
Journaling: enabled after the next checkpoint
Base table for view: yes
Permissions: yes
Integrities: none
Optimizer statistics: yes; see avg count below, more info in the iistats catalog

Column Information:

Column Name	Type	Length	Nulls	Defaults	Key Seq	Avg Count Per Value
tag_id	char	15	yes	null	1	unique
first_obs_date	date		yes	null		unique
first_obs_site	char	3	yes	null		
first_cnfg_seq_nbr	integer	4	no	yes		
first_coil	char	2	no	yes		
first_obs_file	char	12	yes	null		102.0
last_obs_date	date		yes	null		
last_obs_site	char	3	yes	null		
last_cnfg_seq_nbr	integer	4	no	yes		
last_coil	char	2	no	yes		
last_obs_file	char	12	yes	null		

Secondary indexes:

Index Name	Structure	Keyed On
fo_file_x1	btree	first_obs_file
fo_tag_id_x2	btree	first_obs_date, tag_id
fo_tag_id_x3	btree	tag_id

Name: obs_by_day

Owner: pittag
Created: 30-sep-1998 13:10:26
Location: db3
Type: user table
Version: OT2.0
Page size: 2048
Cache priority: 0
Alter table version: 0
Alter table totwidth: 49
Row width: 49
Number of rows: 3115945
Storage structure: btree with unique keys
Compression: none
Duplicate Rows: not allowed
Number of pages: 266279
Overflow data pages: 0
Journaling: enabled after the next checkpoint
Base table for view: yes
Permissions: yes
Integrities: none
Optimizer statistics: yes; see avg count below, more info in the iistats catalog

Column Information:

Column Name	Type	Length	Nulls	Defaults	Key Seq	Avg Count Per Value
obs_day	date		yes	null	3	888.4
obs_site	char	3	yes	null	1	78208.8
tag_id	char	15	yes	null	2	1.5
obs_file	char	15	yes	null		

Secondary indexes:

Index Name	Structure	Keyed On
o_b_d_x1	btree	tag_id, obs_site
o_b_d_x2	btree	obs_day

F4. Test Tag (TST) Sub-Schema

Test Tags are tags that are used to test interrogation and tagging system components. Test tags should not be counted as fish. Test tags are specifically registered to PTAGIS and recorded in the `test_tags` table.

There are two types of test tags: fixed reference tags and variable reference tags. Fixed reference tags are also known as "timer tags". These tags are assigned to a specific coil at an interrogation site. These tags will emit a unique code at periodic (usually every four hours) intervals. Absence of the fixed reference tags at an interrogation site indicates the failure of a system component or the specific antenna coil. Fixed reference tags **MUST** be registered with a specific interrogation `site_code` and `coil_id`.

The variable reference tags are also called stick tags. Stick tags are, by tradition, wooden sticks with PIT tags embedded in one or two ends. These tags are used by system maintainers to test the operation of interrogation coils throughout the system. The stick tags are usually floated in the fishway (usually a flume) through the interrogation coils. The sticks are recovered and used to test other coils. Stick tags are differentiated from timer tags in that they are not assigned to a specific `coil_id` or `interrogation site_code`.

TST Tables: `test_tags`, `test_tag_data`

Table Purpose:

test_tags

The `test_tags` table is the registration table for `tag_ids` that are specifically not to be identified as fish. This table implicitly differentiates fixed reference tags from stick tags by assigning a `site_code` and `coil_id` to fixed reference tags. The IDL process updates the `last_load_int_count` with the number of times that the fixed reference tag was seen at the interrogation site, for each time that the IDL process loads data from this site. If the `last_load_int_count` is zero, then the coil is listed on the "Timer Tag Exception Report". Otherwise, the `last_load_int_count` is used to display the number of timer tag hits on the "Timer Tag Report".

test_tag_data

Any `tag_id` that is registered in the `test_tags` table and is processed during operation of the IDL is inserted into the `test_tag_data` table. This table is useful for verifying operation of facilities at some time in the past, by identifying operation of timer tags or by verifying testing via diagnostics generated by a maintenance technician using test tags.

Table Definitions:

Name: test_tags

Owner: pittag
Created: 30-sep-1998 13:26:58
Location: db1
Type: user table
Version: OI2.0
Page size: 2048
Cache priority: 0
Alter table version: 0
Alter table totwidth: 29
Row width: 29
Number of rows: 2692
Storage structure: hash with unique keys
Compression: none
Duplicate Rows: not allowed
Number of pages: 66
Overflow data pages: 0
Journaling: enabled after the next checkpoint
Base table for view: yes
Permissions: yes
Integrities: none
Optimizer statistics: yes; see avg count below, more info in the iistats catalog

Column Information:

Column Name	Type	Length	Nulls	Defaults	Key Seq	Avg Count Per Value
testtag_id	char	15	yes	null	1	unique
test_cksum	char	2	yes	null		
obs_site	char	3	no	yes		213.5
coil_id	char	3	no	yes		29.4
last_load_int_count	integer	4	no	no		

Secondary indexes:

Index Name	Structure	Keyed On
t_t_x1	btree	obs_site, coil_id

Name: test_tag_data

Owner: pittag
Created: 30-sep-1998 13:14:22
Location: db4
Type: user table
Version: OT2.0
Page size: 2048
Cache priority: 0
Alter table version: 0
Alter table totwidth: 72
Row width: 72
Number of rows: 4889950
Storage structure: btree
Compression: none
Duplicate Rows: not allowed
Number of pages: 446851
Overflow data pages: 0
Journaling: enabled after the next checkpoint
Base table for view: yes
Permissions: yes, including SELECT to ALL
Integrities: none
Optimizer statistics: yes; see avg count below, more info in the iistats catalog

Column Information:

Column Name	Type	Length	Nulls	Defaults	Key Seq	Avg Count Per Value
obs_date	date		yes	null	3	2.2
obs_site	char	3	yes	null	1	273412.2
tag_id	char	15	yes	null	2	2151.9
cksm	char	2	yes	null		
contr	char	2	yes	null		
nreads	integer	4	yes	null		
coil1	char	2	yes	null		
coil2	char	2	yes	null		
coil3	char	2	yes	null		
coil4	char	2	yes	null		
obs_file	char	15	yes	null		

Secondary indexes:

Index Name	Structure	Keyed On
t_t_d_x1	btree	obs_date
t_t_of_x2	btree	obs_file

F5. Site Configuration Management (SCM) Sub-Schema

The Site Configuration Management Schema provides PTAGIS the capability to maintain change history at interrogation sites. For example, McNary (MCJ) installed a new facility that went on-line in 1994. However, prior to that, MCJ was operating a four-monitor interrogation facility. The SCM tool was used to construct a configuration sequence number for the original McNary facility and a subsequent configuration sequence number for the new facility.

The SCM tool maps coils within monitors (collections of coils) to interrogation sites that can change over time.

Interrogation data stored in obs_data and obs_site and obs_main link to specific configuration sequence numbers (cnfg_seq_nbr) found in the SCM schema.

SCM Tables: site, monitor, site_coil

Table Purpose:

site

The site table describes the site. Information about a site includes its long description, site_code, whether or not it is a main site, the current configuration sequence number of the site and other information used by IDL and report sorting processes.

monitor

The monitor table describes monitors (monitors are collections of one or more coils). Monitors are associated with a configuration (they can be added, changed or removed over time) and so they maintain a cnfg_seq_nbr. Monitors can be associated with entry into a fish collection system, or exit from a fish collection system.

site_coil

The site_coil table associates a coil to a monitor for a specific configuration. Each coil within an interrogation site (and current configuration) is unique. The contr_id (controller identifier) is obsolete.

Table Definitions:

Name: site

Owner: pittag
Created: 30-sep-1998 13:28:09
Location: db1
Type: user table
Version: OI2.0
Page size: 2048
Cache priority: 0
Alter table version: 0
Alter table totwidth: 48
Row width: 48
Number of rows: 39
Storage structure: hash with unique keys
Compression: none
Duplicate Rows: not allowed
Number of pages: 18
Overflow data pages: 0
Journaling: enabled after the next checkpoint
Base table for view: yes
Permissions: yes
Integrities: none
Optimizer statistics: yes; see avg count below, more info in the iistats catalog

Column Information:

Column Name	Type	Length	Nulls	Defaults	Key Seq	Avg Count Per Value
obs_site	char	3	no	no	1	unique
site_name	varchar	30	no	yes		
cur_cfg_seq	integer	4	no	yes		
main_y_n	char	1	no	no		
active_y_n	char	1	no	no		
parallel_a_b	char	1	no	no		
poll_y_n	char	1	no	no		
new_data_y_n	char	1	no	no		
max_llint_count	integer	4	no	yes		

Secondary indexes: none

Name: monitor

```

Owner:                pittag
Created:              30-sep-1998 13:14:18
Location:            db1
Type:                user table
Version:             OI2.0
Page size:           2048
Cache priority:      0
Alter table version: 0
Alter table totwidth: 52
Row width:           52
Number of rows:      236
Storage structure:   btree with unique keys
Compression:         none
Duplicate Rows:      not allowed
Number of pages:     15
Overflow data pages: 0
Journaling:          enabled after the next checkpoint
Base table for view: yes
Permissions:         yes
Integrities:         none
Optimizer statistics: yes; see avg count below, more info in the iistats catalog

```

Column Information:

Column Name	Type	Length	Nulls	Defaults	Key Seq	Avg Per	Count Value
obs_site	char	3	no	no	1		5.5
cnfg_seq_nbr	integer	4	no	no	2		44.0
monitor_nbr	integer	4	no	no	3		12.6
monitor_name	varchar	30	no	no			
mon_ctgry_str	char	3	no	yes			
entry_y_n	char	1	no	yes			
exit_y_n	char	1	no	yes			
sort_str	char	4	no	yes			

Secondary indexes: none

Name: site_coil

Owner: pittag
Created: 30-sep-1998 14:11:23
Location: db1
Type: user table
Version: OI2.0
Page size: 2048
Cache priority: 0
Alter table version: 0
Alter table totwidth: 17
Row width: 17
Number of rows: 653
Storage structure: btree with unique keys
Compression: none
Duplicate Rows: not allowed
Number of pages: 23
Overflow data pages: 0
Journaling: enabled after the next checkpoint
Base table for view: yes
Permissions: yes
Integrities: none
Optimizer statistics: yes; see avg count below, more info in the iistats catalog

Column Information:

Column Name	Type	Length	Nulls	Defaults	Key Seq	Avg Per	Count Value
obs_site	char	3	no	no	1		17.0
cnfg_seq_nbr	integer	4	no	no	2		115.0
coil_id	char	3	no	yes	3		4.3
contr_id	char	3	no	yes	4		10.2
monitor_nbr	integer	4	no	no			

Secondary indexes: none

F6. Validation SubSchema (VAL)

Two tables are used to validate user input to PTAGIS in conformance with the Spec Doc.

VAL Tables: *rkm*, *valid_tbl*

Table Purpose:

rkm

The *rkm* table contains the list of valid tagging, release and recapture site codes, associated river kilometers, a revision date and associated messages for administrative and tracking purposes. New entries to this table are submitted by members of the PIT Tag Steering Committee.

valid_tbl

The *valid_tbl* contains a set of domains (e.g., TAG COORD, FLAG CODE) and the associated short code name and the description of the code. These codes are approved by the PIT Tag Steering Committee.

Table Definitions:

Name: *rkm*

```
Owner:                pittag
Created:              30-sep-1998 13:09:54
Location:             db3
Type:                 user table
Version:              OI2.0
Page size:            2048
Cache priority:       0
Alter table version: 0
Alter table totwidth: 276
Row width:            276
Number of rows:       412
Storage structure:    btree
Compression:          none
Duplicate Rows:       allowed
Number of pages:      80
Overflow data pages: 0
Journaling:           enabled after the next checkpoint
Base table for view:  yes
Permissions:          yes
Integrities:          none
Optimizer statistics: yes; see avg count below, more info in the iistats catalog
```

Column Information:

Column Name	Type	Length	Nulls	Defaults	Key Seq	Avg Per	Count Value
modification_date	date		yes	null			
loc_name	char	125	yes	null			
site	char	6	yes	null	1	unique	
fixed_rel_site_y_n	char	1	yes	null			
parent_release_loc	char	6	yes	null			
river_km	char	23	yes	null			
km_tot	integer	4	yes	null			
reach	char	8	yes	null			
modification_message	varchar	80	yes	null			

Secondary indexes: none

Name: valid_tbl

Owner: pittag
Created: 30-sep-1998 13:29:08
Location: db1
Type: user table
Version: OI2.0
Page size: 2048
Cache priority: 0
Alter table version: 0
Alter table totwidth: 98
Row width: 98
Number of rows: 366
Storage structure: btree
Compression: none
Duplicate Rows: allowed
Number of pages: 53
Overflow data pages: 0
Journaling: enabled after the next checkpoint
Base table for view: no
Permissions: yes
Integrities: none
Optimizer statistics: yes; see avg count below, more info in the iistats catalog

Column Information:

Column Name	Type	Length	Nulls	Defaults	Key Seq	Avg Count Per Value
ref_code	char	30	yes	null	2	unique
ref_name	char	45	yes	null		
domain	char	20	yes	null	1	27.8

Secondary indexes: none